

GROUP 11B

ENGINE OVERHAUL

CONTENTS

GENERAL DESCRIPTION	11B-2	ROCKER ARMS AND CAMSHAFT ..	11B-35
SPECIAL TOOLS	11B-4	REMOVAL AND INSTALLATION	11B-35
GENERATOR AND IGNITION SYSTEM	11B-8	INSPECTION.....	11B-39
REMOVAL AND INSTALLATION	11B-8	CYLINDER HEAD AND VALVES	11B-42
SOLENOID AND VACUUM HOSE ..	11B-10	REMOVAL AND INSTALLATION	11B-42
REMOVAL AND INSTALLATION	11B-10	INSPECTION.....	11B-47
TIMING BELT	11B-11	OIL PAN AND OIL PUMP	11B-51
REMOVAL AND INSTALLATION	11B-11	REMOVAL AND INSTALLATION	11B-51
INSPECTION	11B-25	INSPECTION.....	11B-60
FUEL AND EMISSION PARTS	11B-27	PISTON AND CONNECTING ROD ..	11B-61
REMOVAL AND INSTALLATION	11B-27	REMOVAL AND INSTALLATION	11B-61
INTAKE MANIFOLD	11B-29	INSPECTION.....	11B-69
REMOVAL AND INSTALLATION	11B-29	CRANKSHAFT AND CYLINDER	
EXHAUST MANIFOLD	11B-31	BLOCK	11B-70
REMOVAL AND INSTALLATION	11B-31	REMOVAL AND INSTALLATION	11B-70
WATER PUMP & WATER HOSE	11B-33	INSPECTION.....	11B-74
REMOVAL AND INSTALLATION	11B-33	SPECIFICATIONS	11B-76
		FASTENER TIGHTENING	
		SPECIFICATIONS.....	11B-76
		GENERAL SPECIFICATIONS	11B-79
		SERVICE SPECIFICATIONS	11B-80
		SEALANTS AND ADHESIVES	11B-82

GENERAL DESCRIPTION

M1113000100891

4G63 engine used in LANCER EVOLUTION IX adopts MITSUBISHI INNOVATIVE VALVE TIMING ELECTRONIC CONTROL SYSTEM (MIVEC).

MIVEC mechanism is as follows:

V.V.T. (VARIABLE VALVE TIMING) CONTROL SYSTEM

This V.V.T. system consists of the parts indicated in the illustration.

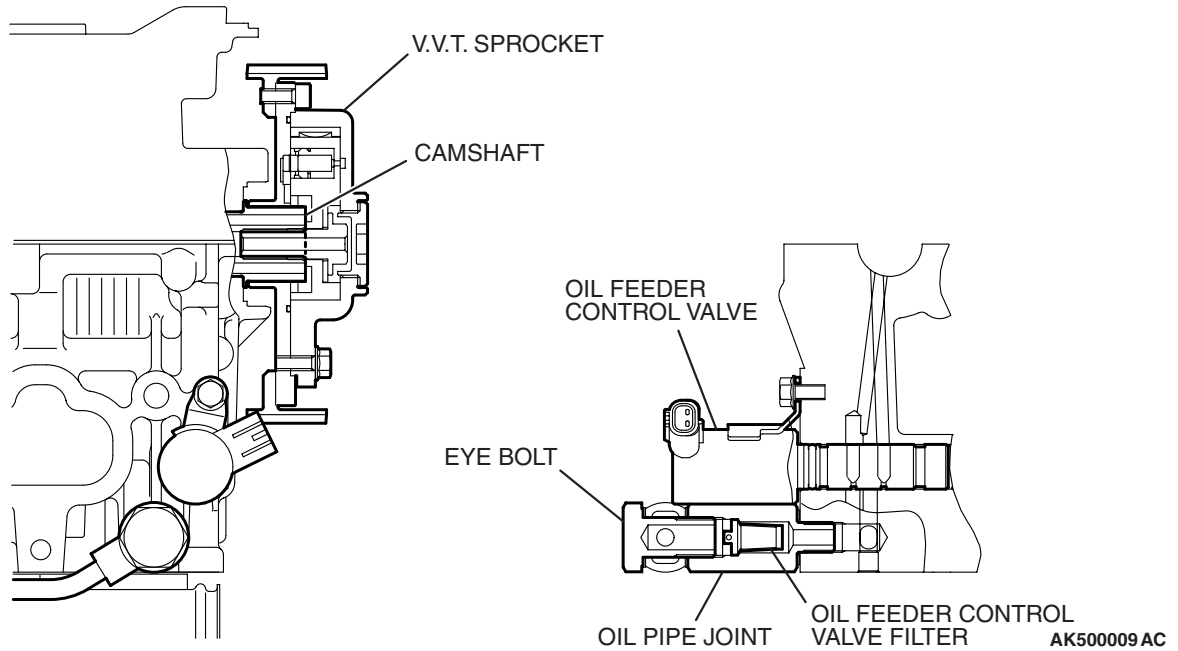

V.V.T. (VARIABLE VALVE TIMING) SPROCKET

This V.V.T. sprocket is installed to change the valve timing through the vane rotor driven by oil pressure from the oil feeder control valve.

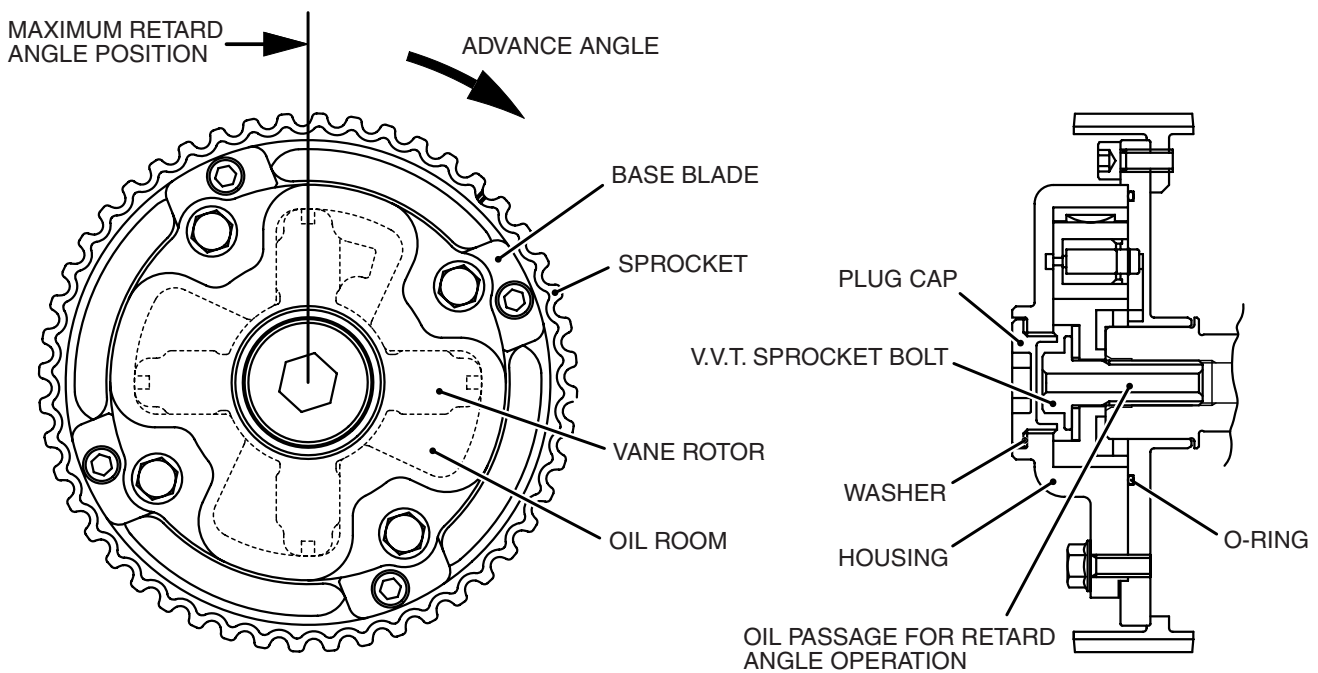

AK501795 AC

CAMSHAFT

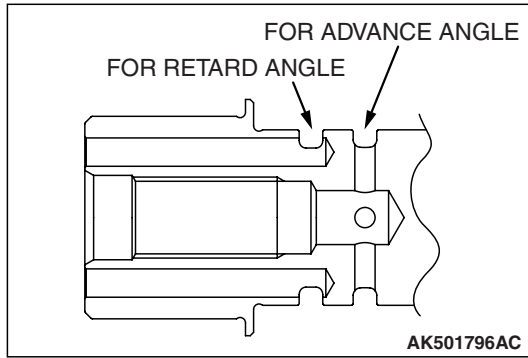

The camshaft has the oil passage to transfer the oil pressure from the oil feeder control valve to the V.V.T. sprocket.

OIL FEEDER CONTROL VALVE (OCV)

This oil feeder control valve uses an electromagnetic valve which switches oil pressure affecting a vane rotor on a V.V.T. sprocket ASSY. This is driven by the signal from the engine ECU.

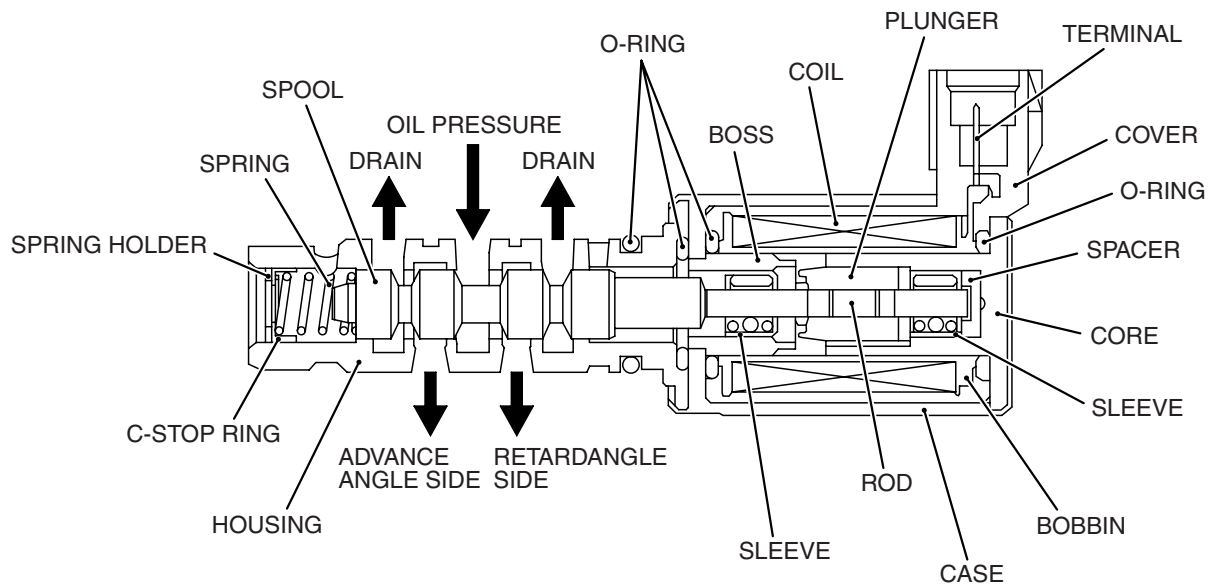

AK201866AD

SPECIAL TOOLS

M1113000601413

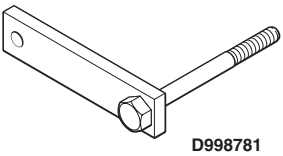
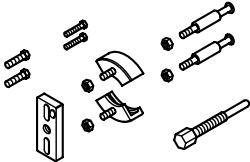
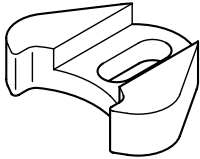
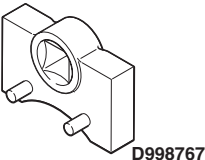
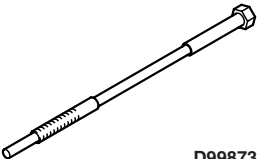
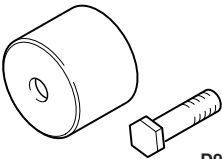
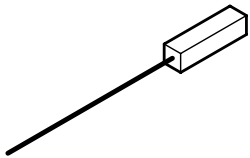
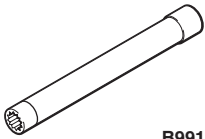
TOOL	TOOL NUMBER AND NAME	SUPERSESSION	APPLICATION
 D998781	MD998781 Flywheel stopper	General service tool	Supporting flywheel and drive plate
	MD998778 Crankshaft sprocket puller	General service tool	Removal of crankshaft sprocket
	MD998785 Sprocket stopper	MD998785	Supporting counterbalance shaft sprocket
 D998767	MD998767 Tension pulley wrench	MD998752-01	Adjustment of timing belt tension
 D998738	MD998738 Adjusting screw	General service tool	<ul style="list-style-type: none"> • Holding the auto-tensioner • Timing belt tension adjustment
 D998713	MD998713 Camshaft oil seal installer	MD998713-01	Installation of camshaft oil seal
	MD998442 Air bleed wire	General service tool	Air bleed of lash adjuster
 B991654	MB991654 Cylinder head bolt wrench (12)	General service tool	Removal and installation of cylinder head bolt

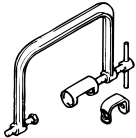
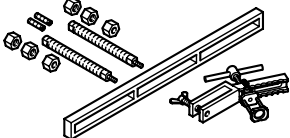
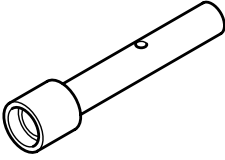
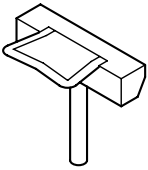
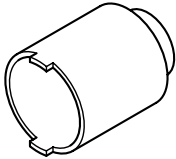
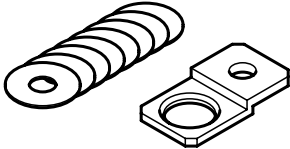
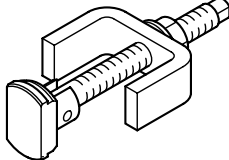
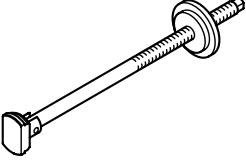
TOOL	TOOL NUMBER AND NAME	SUPERSESION	APPLICATION
	MD998735 Valve spring compressor	MD998735-01	Compression of valve spring
	MD998772 Valve spring compressor	MLR-MD998772 or General service tool	Compression of valve spring
	MD998737 Valve steam seal installer	MD998737-01	Installation of valve steam seal
 <p align="right">D998727</p>	MD998727 Oil pan remover	MD998727-01	Removal of oil pan
	MD998162 Plug wrench Use with MD998783	MD998162-01	Removal and installation of front case cap plug
	MD998783 Plug wrench retainer	General service tool	
	MD998371 Silent shaft bearing puller	MD998371-01	Removal of counterbalance shaft front bearing
	MD998372 Silent shaft bearing puller	MD998372-01	Removal of counterbalance shaft rear bearing

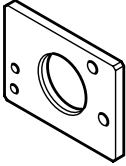
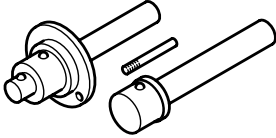
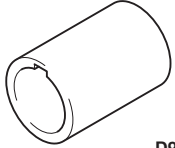
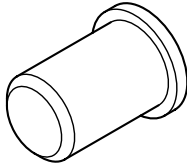
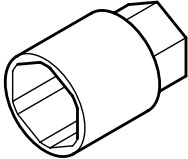
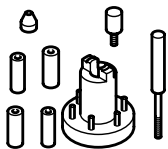
TOOL	TOOL NUMBER AND NAME	SUPERSESION	APPLICATION
	MB991603 Bearing installer stopper	General service tool	Removal and installation of rear bearing
	MD998705 Silent shaft bearing installer	MD998373-01 Use with MB990938-01	Installation of counterbalance shaft bearing
 <p data-bbox="337 804 407 825">D998285</p>	MD998285 Crankshaft front oil seal guide	MD998285-01	Installation of crankshaft front oil seal
	MD998375 Crankshaft front oil seal installer	MD998375-01	
	MD998012 Oil pressure switch wrench	-	Removal and installation of engine oil pressure switch
	MD998780 Piston pin setting tool	MIT216941	Removal and installation of piston pin

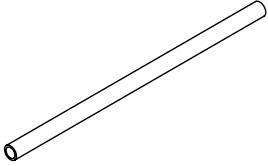
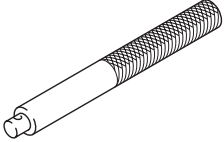
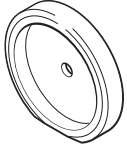
TOOL	TOOL NUMBER AND NAME	SUPERSESION	APPLICATION
	MB992010 Bolt guide	–	Removal and installation of piston and connecting rod assembly
	MB990938 Handle	MB990938-01	Installation of crankshaft rear oil seal
 <p data-bbox="342 806 418 827">D998776</p>	MD998776 Crankshaft rear oil seal installer	MD998376-01	

GENERATOR AND IGNITION SYSTEM

REMOVAL AND INSTALLATION

M1113001000994

CAUTION

Do not remove the ignition coil boot from the ignition coil except the replacement. When removing the ignition coil boot, always replace it with the new one.

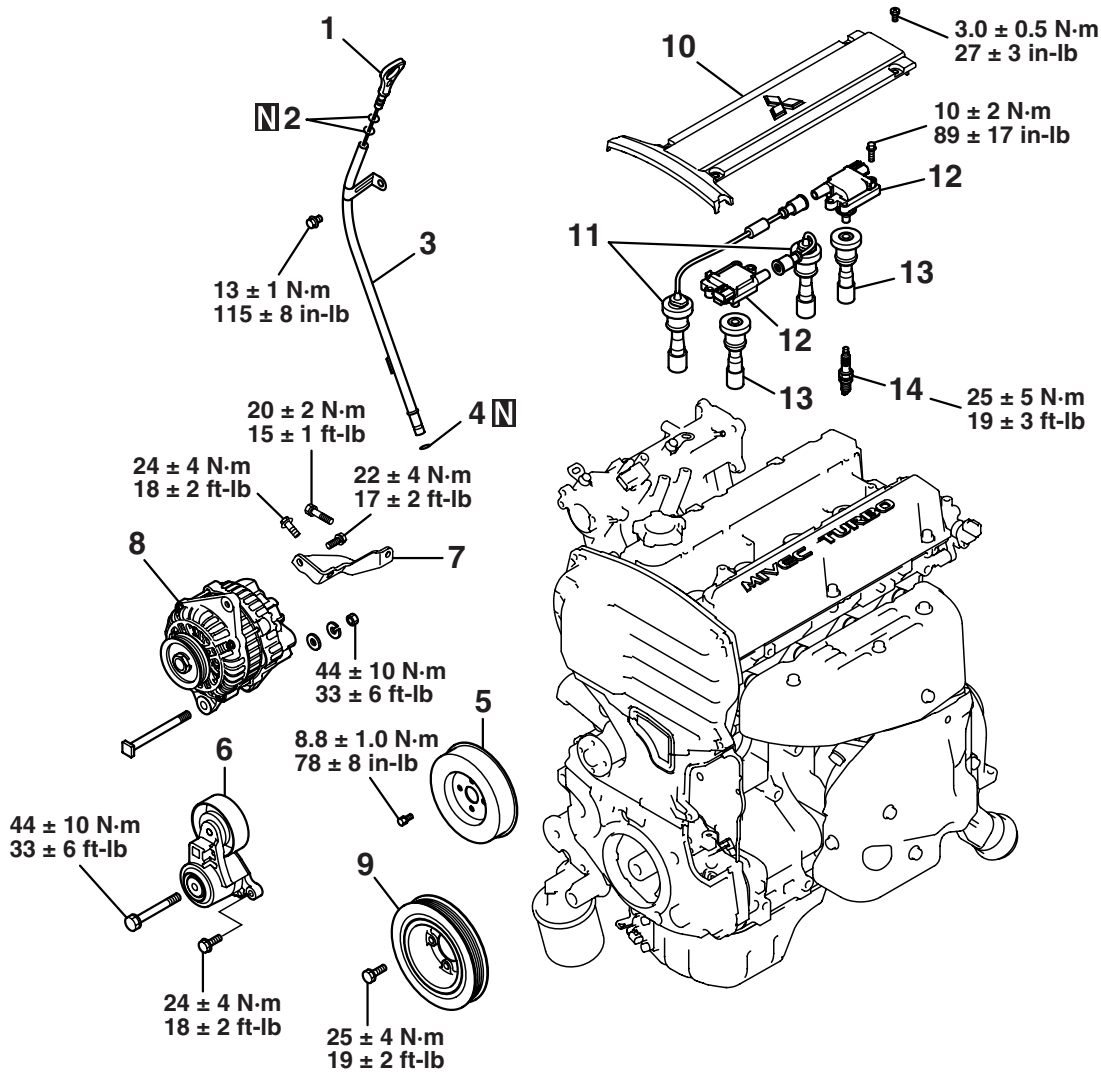

AK501910AB

REMOVAL STEPS

1. OIL DIPSTICK
2. O-RING
3. OIL DIPSTICK GUIDE
4. O-RING
5. AUTO-TENSIONER
6. WATER PUMP PULLEY
7. GENERATOR BRACE

REMOVAL STEPS (Continued)

8. GENERATOR
9. CRANKSHAFT PULLEY
10. CENTER COVER
11. SPARK PLUG CABLE
12. IGNITION COIL
- >>A<< 13. IGNITION COIL BOOT
14. SPARK PLUG

INSTALLATION SERVICE POINTS

>>A<< IGNITION COIL BOOT INSTALLATION

⚠ CAUTION

- When the ignition coil boot is not installed as indicated, realize that it would be possibly the causes of the malfunctions which lead to an inappropriate ignition coil operation, a damaged ignition coil, a high voltage leakage toward the outside and water immersion into the hole.
- White powders are applied to the fitting area of the spark plug on the ignition coil boot in order to prevent the fitting area from baking onto the spark plug. Do not touch or clean them.

1. Confirm the spring is attached to the new ignition coil boot inside.
2. Push and install the new ignition coil boot into the ignition coil without a clearance, turning the fitting area twice or three times.
3. After the installation, turn the ignition coil boot so that the air bleeding hole can be in position indicated in the illustration.

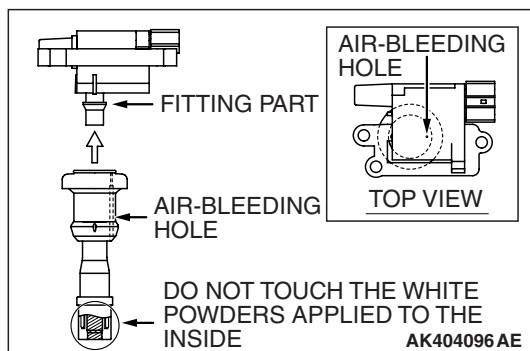

SOLENOID AND VACUUM HOSE**REMOVAL AND INSTALLATION**

M1113025300126

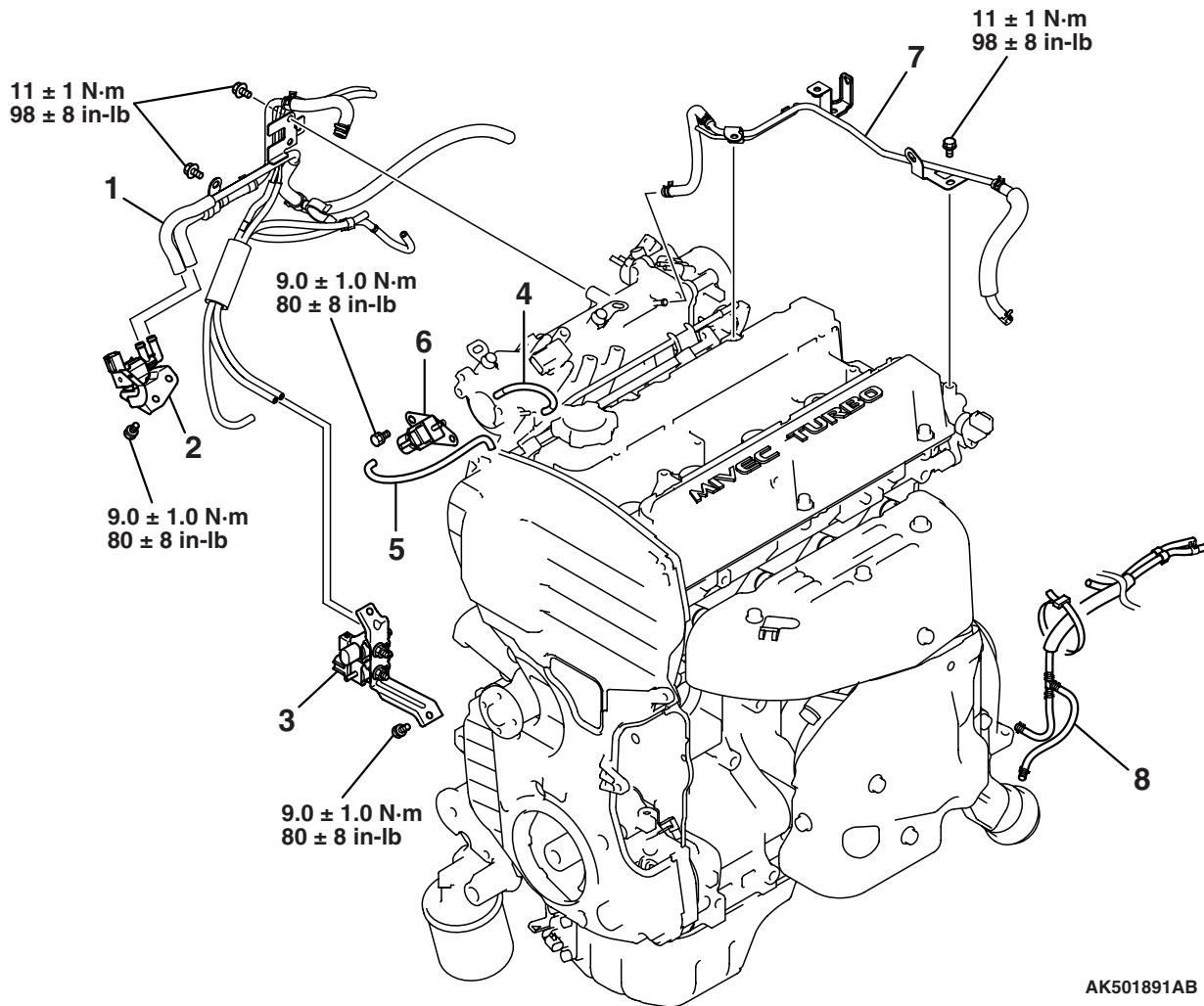

AK501891AB

REMOVAL STEPS

1. VACUUM PIPE AND HOSE ASSEMBLY
2. SOLENOID VALVE
3. SOLENOID VALVE
4. VACUUM HOSE

REMOVAL STEPS (Continued)

5. VACUUM HOSE
6. SOLENOID VALVE
7. VACUUM PIPE AND HOSE ASSEMBLY
8. VACUUM HOSE ASSEMBLY

TIMING BELT

REMOVAL AND INSTALLATION

M1113001901149

CAUTION

Never overhaul the V.V.T. sprocket.

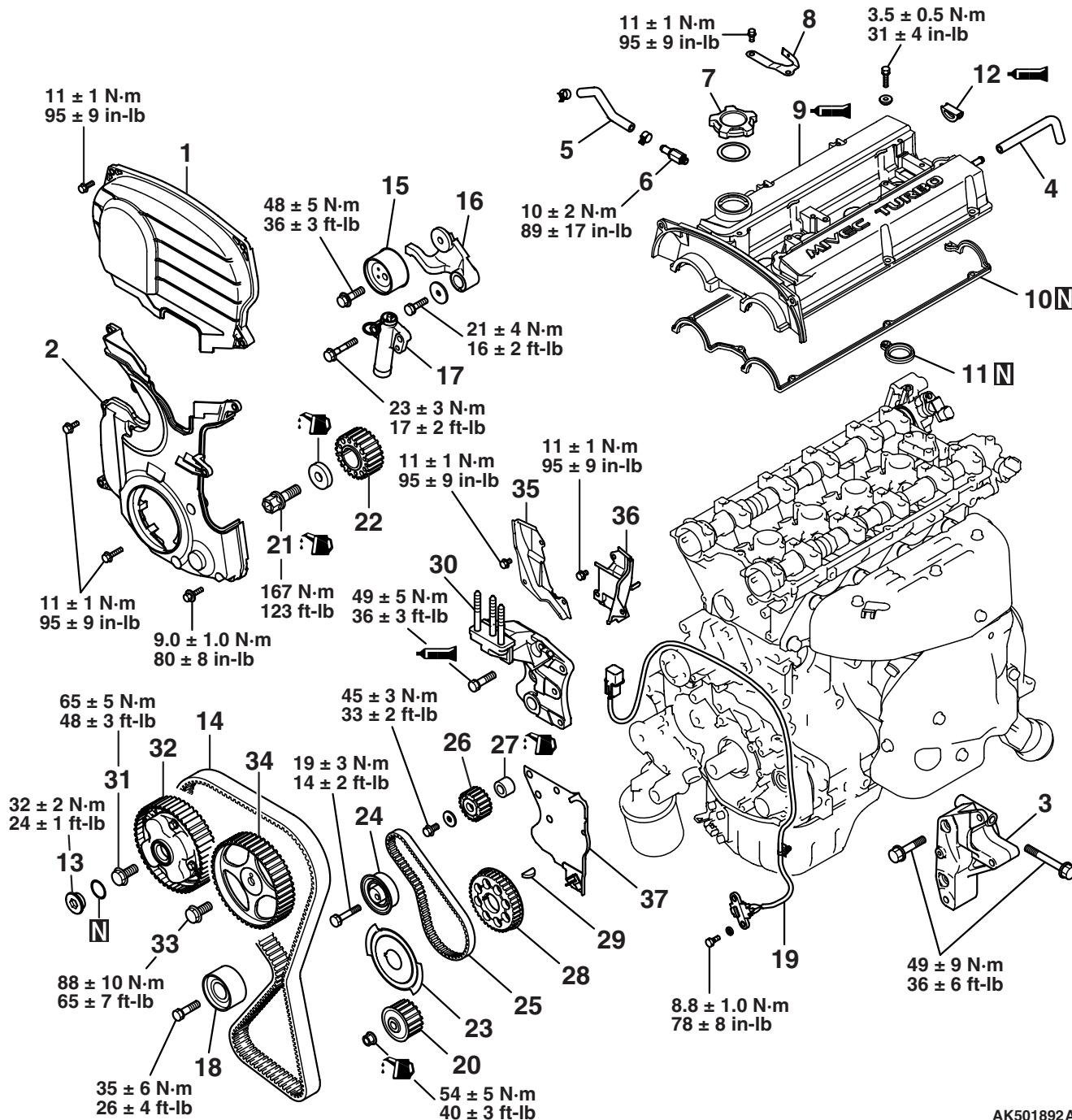

AK501892AB

Removal steps

1. TIMING BELT FRONT UPPER COVER
2. TIMING BELT FRONT LOWER COVER
3. POWER STEERING PUMP BRACKET
4. BREATHER HOSE
5. PCV HOSE
6. PCV VALVE

Removal steps (Continued)

7. OIL FILLER CAP
8. CONNETOR BRACKET
- >>O<< 9. ROCKER COVER
- >>O<< 10. ROCKER COVER GASKET "A"
11. ROCKER COVER GASKET "B"
- >>N<< 12. SEMICIRCULAR PACKING

Removal steps (Continued)

- <<A>> >>M<< 13. PLUG CAP
- <> >>L<< 14. TIMING BELT
- >>K<< 15. TENSIONER PULLEY
- 16. TENSIONER ARM
- >>J<< 17. AUTO-TENSIONER
- 18. IDLER PULLEY
- 19. CRANKSHAFT ANGLE SENSOR
- <<C>> >>I<< 20. OIL PUMP SPROCKET
- <<D>> >>H<< 21. CRANKSHAFT BOLT
- <<E>> >>H<< 22. CRANKSHAFT SPROCKET
- >>H<< 23. CRANKSHAFT SENSING BLADE
- 24. TENSIONER "B"
- <<F>> >>G<< 25. TIMING BELT "B"

Removal steps (Continued)

- <<G>> >>F<< 26. COUNTERBALANCER SHAFT SPROCKET
- >>E<< 27. SPACER
- <<H>> >>D<< 28. CRANKSHAFT SPROCKET "B"
- 29. CRANKSHAFT KEY
- >>C<< 30. ENGINE SUPPORT BRACKET
- <<I>> >>B<< 31. V.V.T. SPROCKET BOLT
- >>B<< 32. V.V.T. SPROCKET
- <<J>> >>A<< 33. CAMSHAFT SPROCKET BOLT
- 34. CAMSHAFT SPROCKET
- 35. TIMING BELT REAR COVER, RIGHT
- 36. TIMING BELT REAR UPPER COVER, LEFT
- 37. TIMING BELT REAR LOWER COVER, LEFT

Required Special Tools:

- MD998738: Adjusting Screw
- MD998767: Tensioner Pulley Wrench
- MD998778: Crankshaft Sprocket Puller
- MD998781: Flywheel Stopper
- MD998785: Sprocket Stopper

REMOVAL SERVICE POINTS

<<A>> PLUG CAP REMOVAL

Loosen the plug cap, holding the hexagonal portion of the camshaft with a wrench.

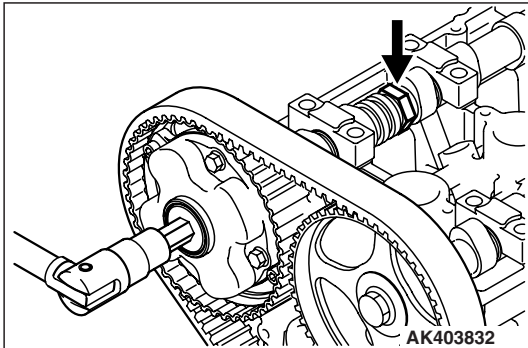

<> TIMING BELT REMOVAL

1. If the timing belt is to be reused, make an arrow mark with something like chalk on the back of the belt indicating the direction of rotation so it may be reinstalled in the same direction.

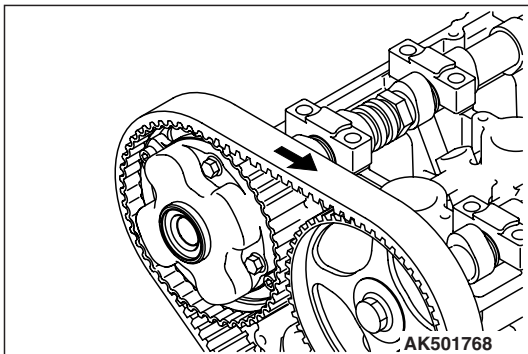

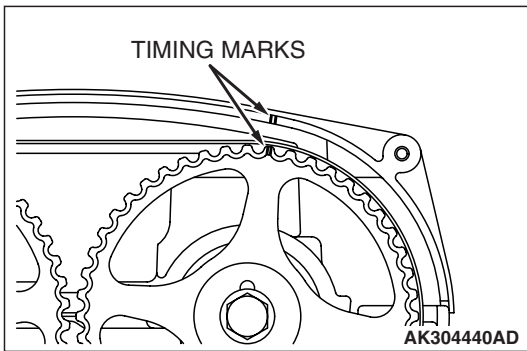

⚠ CAUTION

Never remove the timing belt with any piston at the top dead center (TDC). If a piston is at TDC, the exhaust valves of the cylinder are pushed by the exhaust cams, compressing the valve springs. If the belt is removed under this condition, the sprocket will be turned in the reverse direction by the force of the springs, incurring risk of injury to person.

2. Set the timing mark of the exhaust camshaft sprocket to a point about one tooth before the TDC of the No.1 cylinder piston on compression stroke.
3. Loosen the lock nut of the tensioner pulley, then remove the timing belt.

<<C>> OIL PUMP SPROCKET REMOVAL

1. Remove the plug on the left side of the cylinder block.
2. Insert a Phillips crosspoint screwdriver [shank diameter 8 mm (0.3 inch)] through the plug hole to block the left counterbalance shaft.
3. Loosen the nut, and then remove the oil pump sprocket.

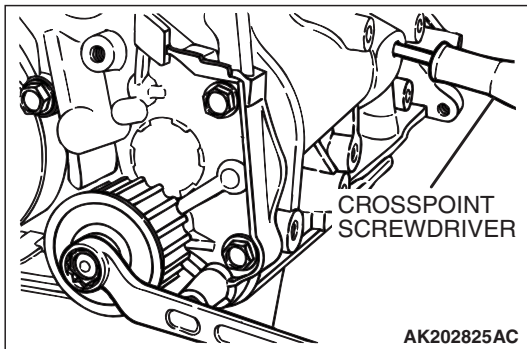
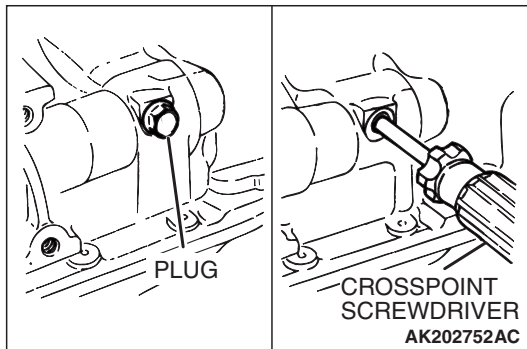

<<D>> CRANKSHAFT BOLT LOOSENING

1. Install special tool MD998781 to hold the flywheel or drive plate.
2. Loosen and remove the crankshaft bolt and washer.

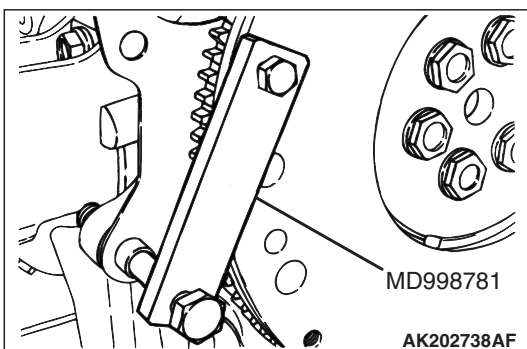

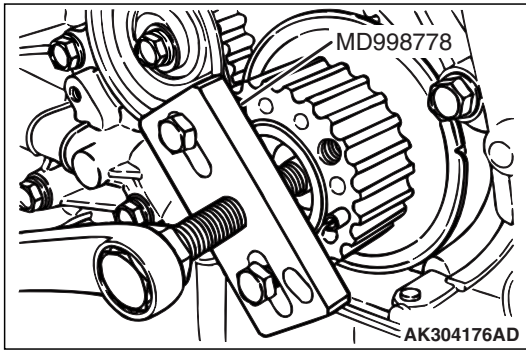
**<<E>> CRANKSHAFT SPROCKET REMOVAL**

1. Set special tool MD998778 as shown in the illustration.
2. Screw in the center bolt of the special tool to remove the crankshaft sprocket.

<<F>> TIMING BELT "B" REMOVAL**⚠ CAUTION**

Water or oil on the belt shortens its life drastically, so the removed timing belt, sprocket, and tensioner must be free from oil and water. These parts should not be washed or immersed in solvent. Replace parts if contaminated. If there is oil or water on each part, check the front case oil seals, camshaft oil seal and water pump for leaks.

1. Mark the belt running direction for reinstallation.
2. Loosen the tensioner "B" bolt, and then remove the timing belt "B."

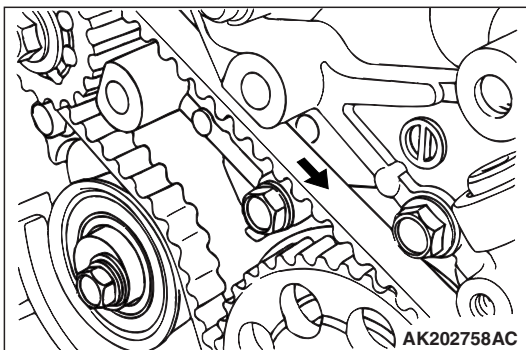
**<<G>> COUNTERBALANCE SHAFT SPROCKET REMOVAL**

1. Set special tool MD998785 as shown to prevent the counterbalance shaft sprocket from turning together.
2. Loosen the bolt and remove the sprocket.

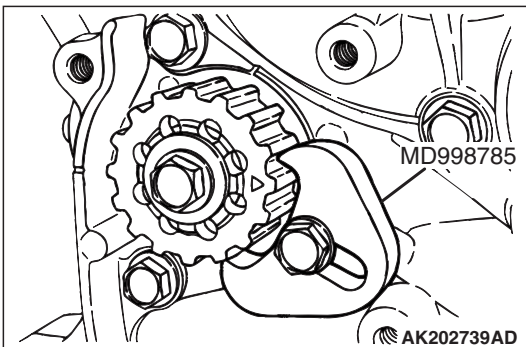

<<H>> CRANKSHAFT SPROCKET "B" REMOVAL

1. Set special tool MD998778 as shown in the illustration.
2. Screw in the center bolt of the special tool to remove crankshaft sprocket "B."

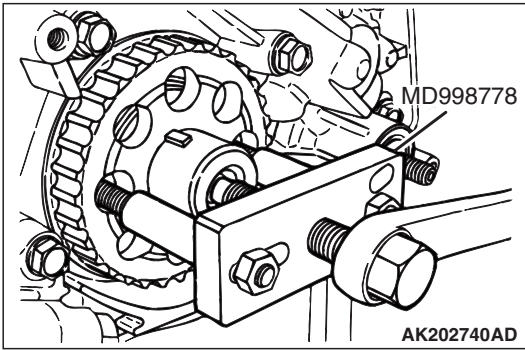

<<I>> V.V.T. SPROCKET BOLT REMOVAL

Loosen the V.V.T. sprocket bolt, holding the hexagonal portion of the camshaft with a wrench.

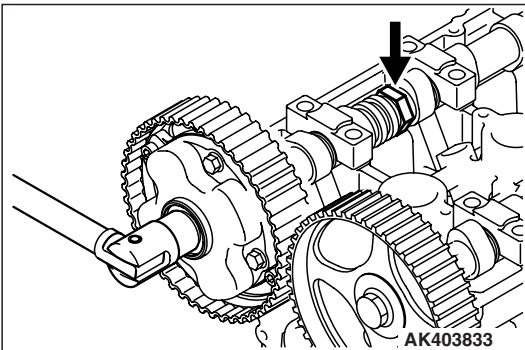

<<J>> CAMSHAFT SPROCKET REMOVAL

Remove the camshaft sprocket bolt while preventing the camshaft from rotation using a wrench fitted on the hexagonal portion of the camshaft.

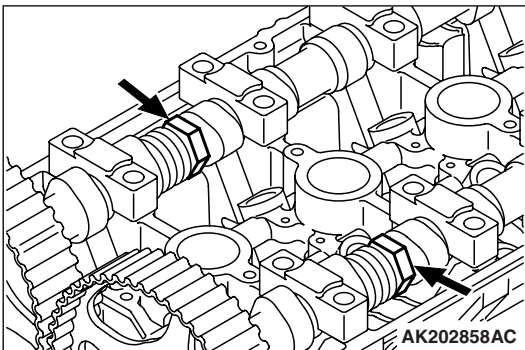

INSTALLATION SERVICE POINTS

>>A<< CAMSHAFT SPROCKET INSTALLATION

Tighten the camshaft sprocket bolt while preventing the camshaft from rotation using a wrench fitted on the hexagonal portion of the camshaft.

Tightening torque: 88 ± 10 N·m (65 ± 7 ft-lb)

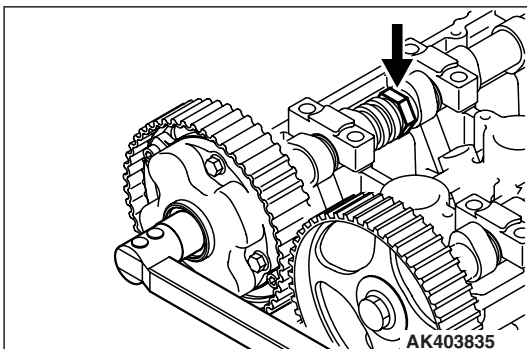
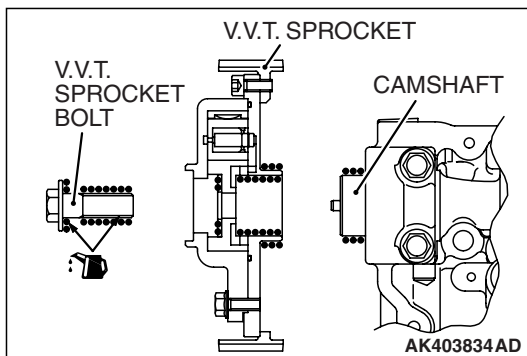
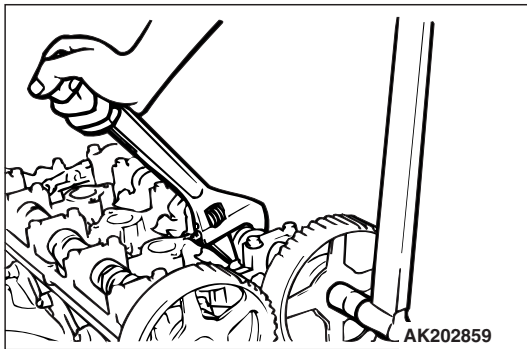
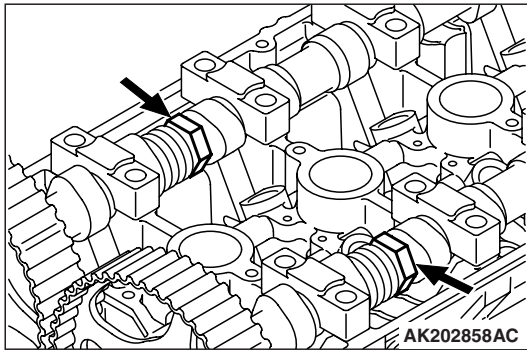
>>B<< V.V.T. SPROCKET / V.V.T. SPROCKET BOLT
INSTALLATION

1. Apply minimum amount of engine oils adequately to the following portions.
 - All directions of camshaft top
 - Inner and outer surfaces of place in which V.V.T. sprocket is inserted
 - Threads and top seat of V.V.T. sprocket bolt
 - V.V.T. sprocket bolt seat
2. Install the V.V.T. sprocket.
3. Firmly and deeply insert the V.V.T. sprocket, and then confirm the V.V.T. sprocket is not rotated, holding the hexagonal portion of the camshaft with a wrench.
4. Holding the hexagonal portion of the camshaft with a wrench, tighten the V.V.T. sprocket bolt to the specified torque of 65 ± 5 N·m.
5. Holding the hexagonal portion of the camshaft with a wrench, confirm the V.V.T. sprocket is not rotated.

NOTE: This shows the V.V.T. sprocket being locked at the most retarded angle with the inside pin.

>>C<< ENGINE SUPPORT BRACKET INSTALLATION

Coat the threads of the seal bolt A in the illustration with 3M™ AAD Part number 8672 or equivalent before tightening.

Tightening torque: 49 ± 5 N·m (36 ± 3 ft-lb)

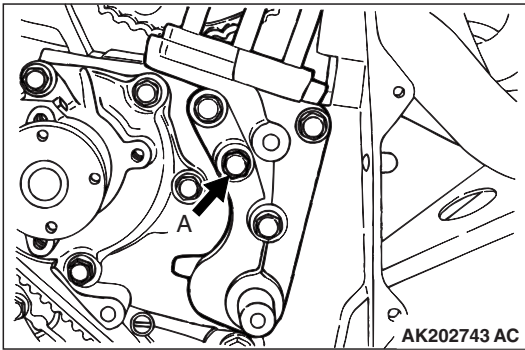

>>D<< CRANKSHAFT SPROCKET "B" INSTALLATION

Clean and then degrease the front case of the front case, crankshaft sprocket "B" and crankshaft surface on which sprocket "B" is attached.

NOTE: Degreasing is necessary to prevent decrease in the friction between contacting surfaces.

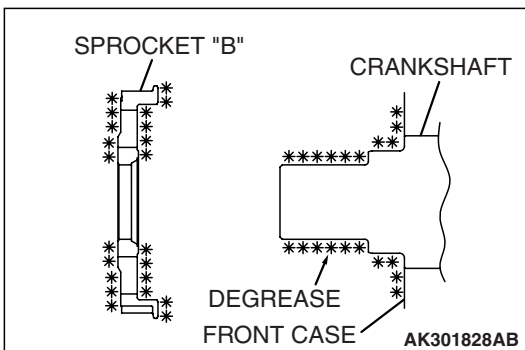

>>E<< SPACER INSTALLATION

1. Apply a thin coat of clean engine oil to the lip area of the oil seal.
2. Install the spacer with the chamfered end facing toward the oil seal.

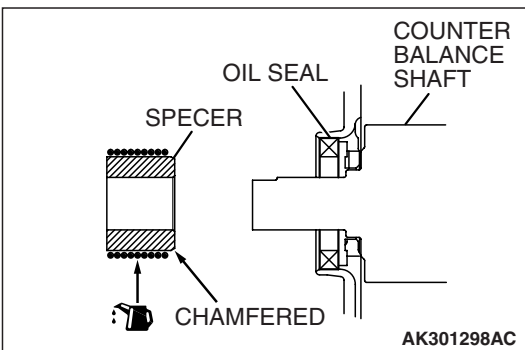

>>F<< COUNTERBALANCE SHAFT SPROCKET INSTALLATION

1. Install the counterbalance shaft sprocket and screw in the bolt.
2. Install special tool MD998785 as shown in the illustration to lock the counterbalance shaft.
3. Tighten the bolt, and then remove the special tool.

Tightening torque: 45 ± 3 N·m (33 ± 2 ft-lb)

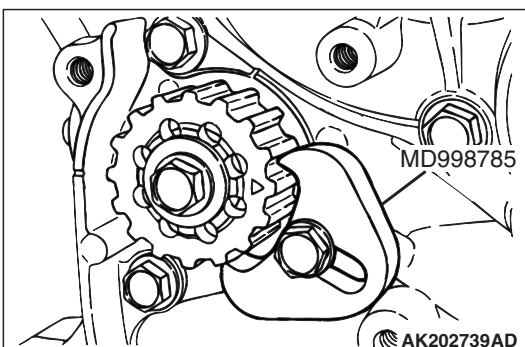

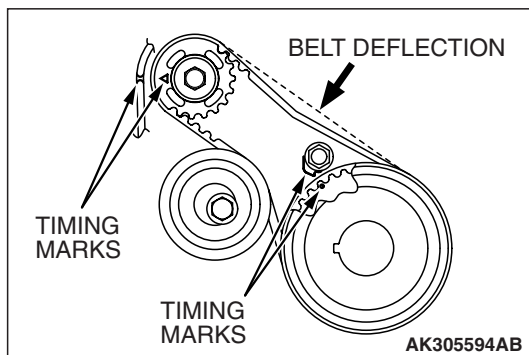
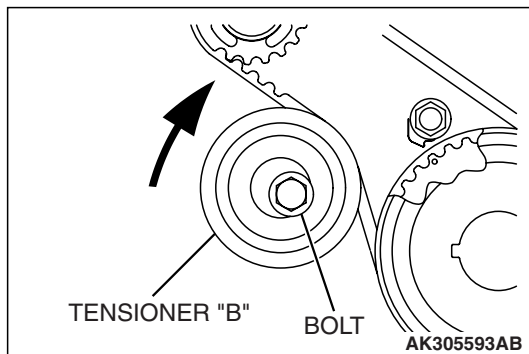
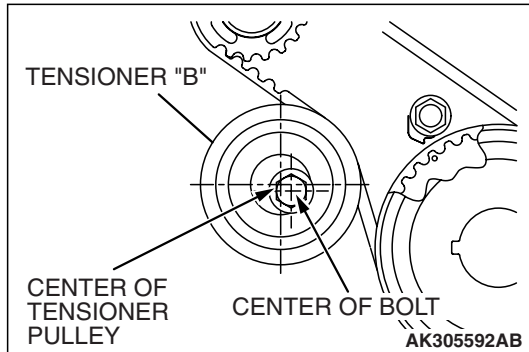
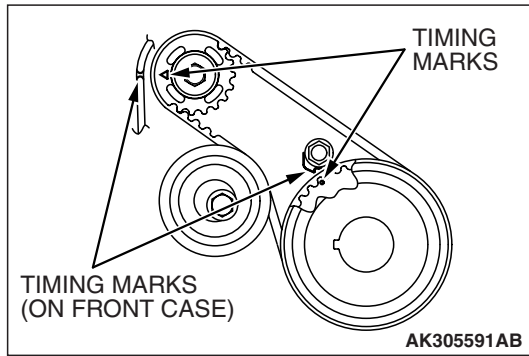
**>>G<< TIMING BELT "B" INSTALLATION**

1. Align timing marks on the crankshaft sprocket "B" and counterbalance shaft sprocket with the marks on the front case.
2. Install the timing belt "B" on the crankshaft sprocket "B" and counterbalance shaft sprocket. There should be no slack on the tension side.
3. Make sure that the relationship between the tensioner pulley center and the bolt center is as shown in the illustration.
4. Move tensioner "B" in the direction of the arrow while lifting with your finger to give sufficient tension to the tension side of timing belt. In this condition, tighten the bolt to secure tensioner "B." When the bolt is tightened, use care to prevent the tensioner pulley shaft from turning with the bolt. If the shaft is turned with the bolt, the belt will be over tensioned.

Tightening torque: $19 \pm 3 \text{ N} \cdot \text{m}$ ($14 \pm 2 \text{ ft-lb}$)
5. Check that timing marks on the sprockets are aligned with the timing marks on the front case.
6. With your index finger, press the midway of the span on the tension side of timing belt "B." The bolt must deflect 5 to 7 mm (0.20 to 0.28 inch).

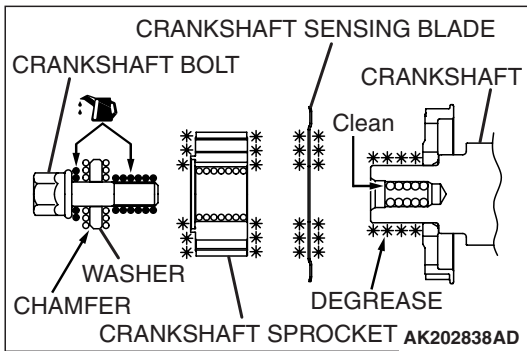

>>H<< CRANKSHAFT SENSING BLADE/CRANKSHAFT SPROCKET/CRANKSHAFT BOLT INSTALLATION

1. Clean and then degrease the contacting surfaces of the crankshaft sprocket, sensing blade and crankshaft.
NOTE: Degreasing is necessary to prevent decrease in the friction between contacting surfaces.
2. Clean the bolt hole in the crankshaft, the crankshaft contacting surface of the crankshaft sprocket, and the washer.
3. Install the sensing blade and the crankshaft sprocket to the crankshaft.
4. Apply small amount of oil to the threads and seating surface of the crankshaft bolt.
5. Install the washer to the crankshaft bolt with its largely chamfered side toward the bolt head.
6. Lock the flywheel using the special tool MD998781.
7. Tighten the crankshaft bolt to the specified torque.

Tightening torque: 167 N·m (123 ft-lb)

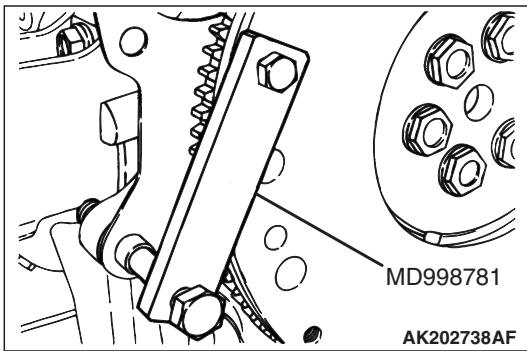

>>I<< OIL PUMP SPROCKET INSTALLATION

1. Insert a Phillips head screwdriver [shank diameter 8 mm (0.3 inch)] through the plug hole on the left side of the cylinder block to block the left counterbalance shaft.
2. Install the oil pump sprocket.
3. Apply a thin coat of engine oil to the seating surface of the nut.
4. Tighten the nut to the specified torque.

Tightening torque: 54 ± 5 N·m (40 ± 3 ft-lb)

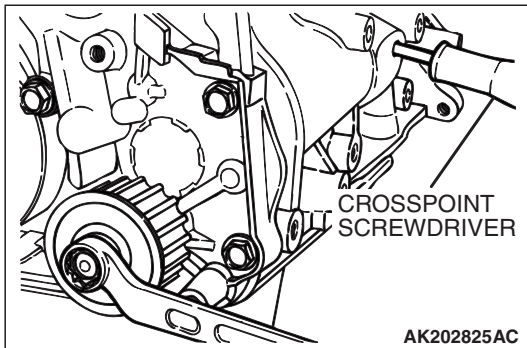

>>J<< AUTO-TENSIONER INSTALLATION

1. If the auto-tensioner rod remains in its fully extended position, reset it to the retracted position as follows:
 - (1) Clamp the auto-tensioner in a vise at right angles to the jaws.
 - (2) Push in the rod little by little with the vise until the set hole A in the rod is aligned with the set hole B in the cylinder.
 - (3) Insert a piece of wire [1.4 mm (0.055 inch) diameter] into the set holes.
 - (4) Remove the auto-tensioner from the vise.

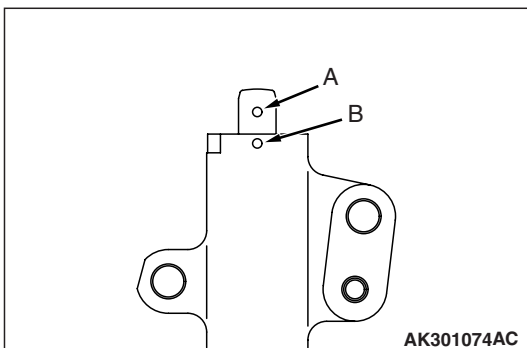

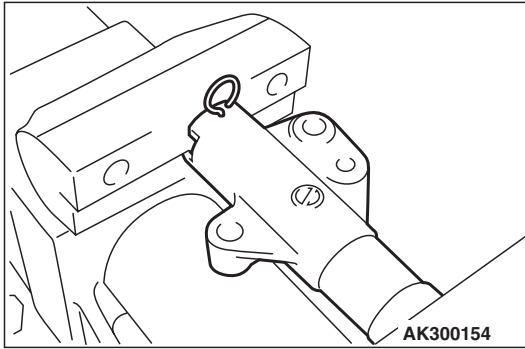

2. Install the auto-tensioner in position. Leave the wire installed until the auto-tensioner is completely installed.

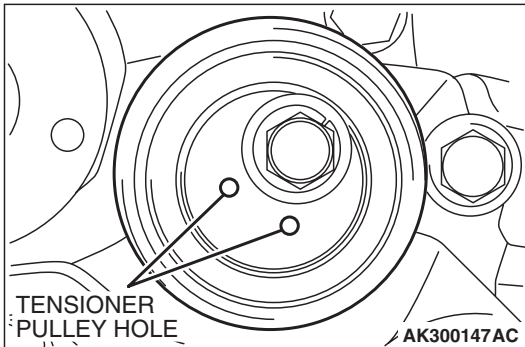

>>K<< TENSIONER PULLEY INSTALLATION

Install the tensioner pulley with its holes aligned as shown in the illustration.

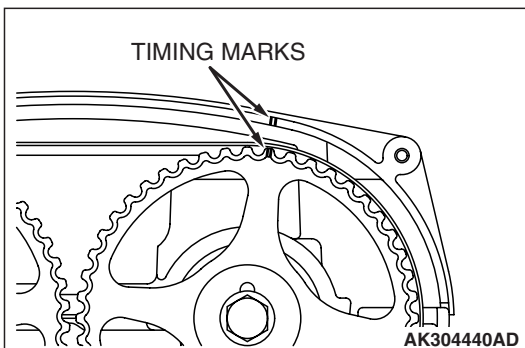

>>L<< TIMING BELT INSTALLATION

1. Bring the timing mark on the exhaust camshaft sprocket to a point one sprocket tooth away from the timing mark on the rocker cover in the counterclockwise direction.

NOTE: If the timing marks were aligned, the exhaust camshaft would be turned counterclockwise by one sprocket tooth and stay there by the force of the valve springs.

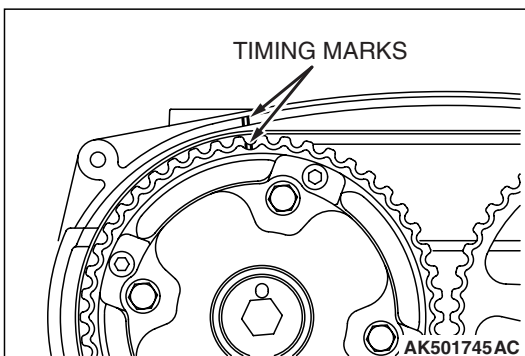

2. Align the timing mark on the intake camshaft sprocket with that on the rocker cover.

NOTE: The intake camshaft will be turned slightly clockwise from where the timing marks are aligned by the force of the valve springs and stay there.

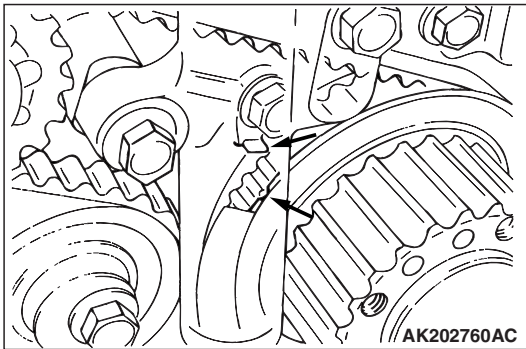

3. Bring the timing mark on the crankshaft sprocket to a point one sprocket tooth away from the mating timing mark in the counterclockwise direction like in the operation with the exhaust camshaft sprocket.

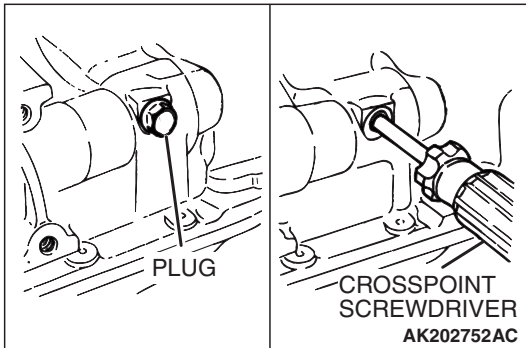

4. Align the timing mark on the oil pump sprocket with that on the cylinder block.
 - (1) Remove the plug from the cylinder block.
 - (2) Insert a crosspoint screwdriver with a shank diameter of 8 mm (2.36 inches) or more, through the plug hole. If it can be inserted 60 mm (2.36 inches) or more, the sprocket is in the correct phase. If the insertion depth is up to 20 –25 mm (0.78 – 0.98 inch), the screwdriver is blocked by the counterbalancer shaft. Then turn the oil pump sprocket one turn and realign the timing marks. Then check that the screwdriver can be inserted 60 mm (2.36 inches) or more. Keep the screwdriver inserted until installation of timing belt is finished.
 - (3) Turn the oil pump sprocket counterclockwise by one sprocket tooth.

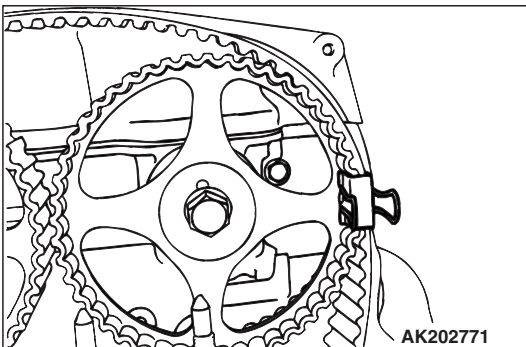
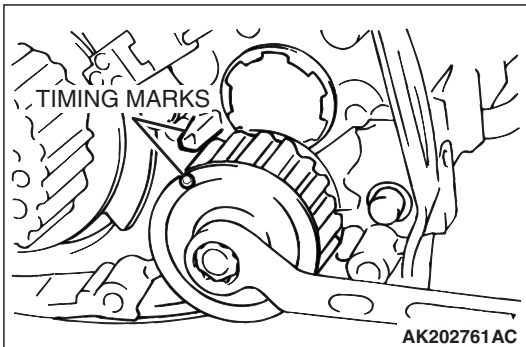

5. Install the timing belt on the exhaust camshaft sprocket, and hold it in place with a paper clamp at the point indicated in the illustration.

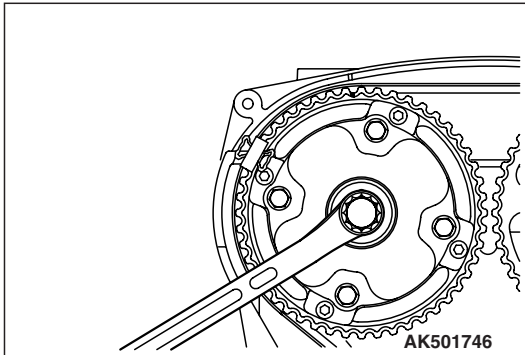

6. Turn the intake camshaft sprocket counterclockwise to bring the timing mark on it one sprocket tooth away from the mating timing mark in the counterclockwise direction. Then install the timing belt on the sprocket and hold it in place with a paper clamp.

NOTE: The timing marks will be aligned when the belt is installed since the intake camshaft is turned slightly clockwise by the force of the valve springs.

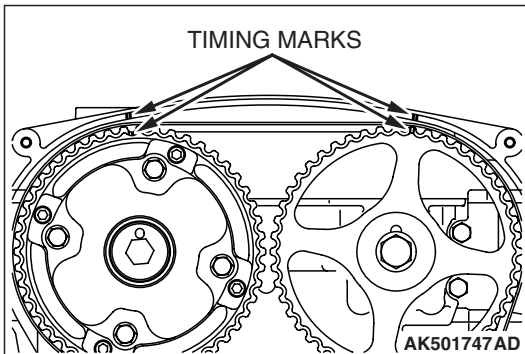

7. Turn the exhaust camshaft sprocket clockwise to align the timing marks, and make sure that the intake camshaft sprocket timing marks are also aligned.

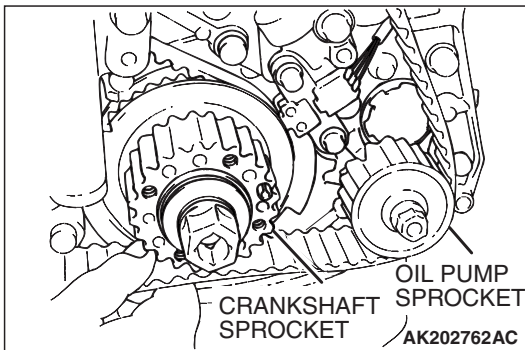

8. Install the timing belt on the idler pulley, oil pump sprocket, and crankshaft sprocket, in this order.

NOTE: There should be no slack in the installed portion of the belt.

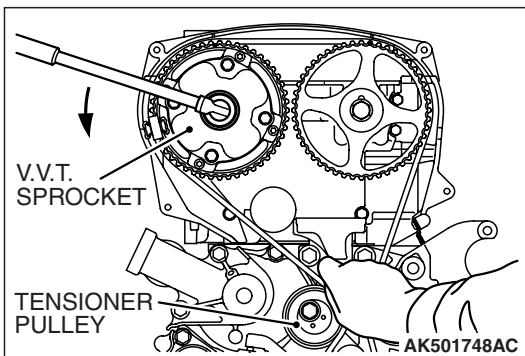

9. Install the timing belt on the tensioner pulley.

NOTE: Turning slightly the intake camshaft sprocket counterclockwise will facilitate installation of the belt on the tensioner pulley.

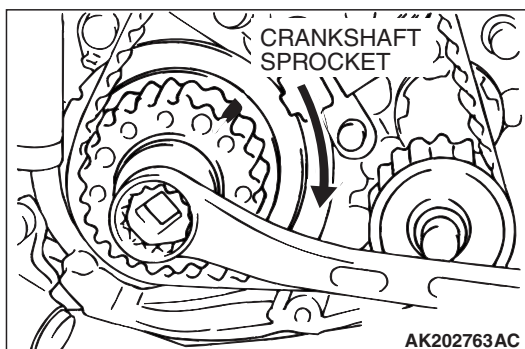

10. Turn the crankshaft sprocket slightly clockwise to take up the slack in the idler pulley portion of the timing belt.

11. Check that each of the timing marks on the crankshaft, oil pump, and exhaust camshaft sprockets is one sprocket tooth away from its mating timing mark in the counterclockwise direction.

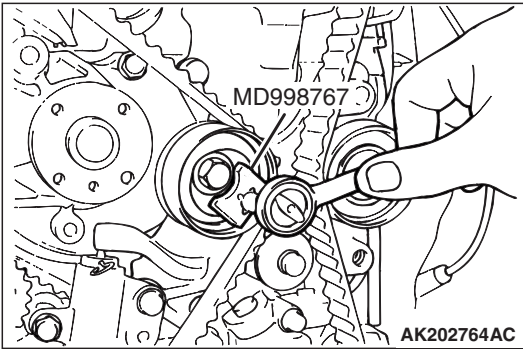

12. Turn the tensioner pulley counterclockwise using the special tool MD998767 to give tension to the belt and hold the tensioner in position by temporarily tightening the tensioner lock bolt.

NOTE: Take up the slack in the belt portion between the intake and exhaust camshaft sprockets.

13. Turn the crankshaft clockwise to make the timing mark align with the No.1 cylinder top dead center mark.

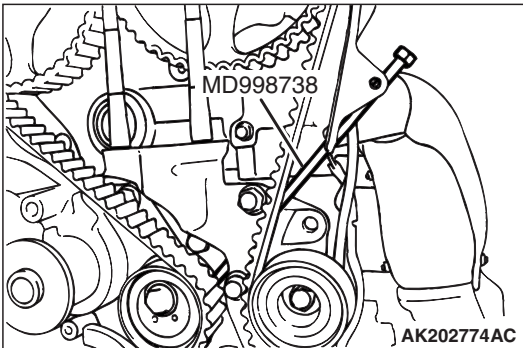

14. Install the special tool MD998738 and turn down the tool until the wire (inserted in the auto-tensioner when it was installed) can be moved freely.

CAUTION

Prevent the timing belt from slipping as it becomes loose following rotation of the intake and exhaust camshafts.

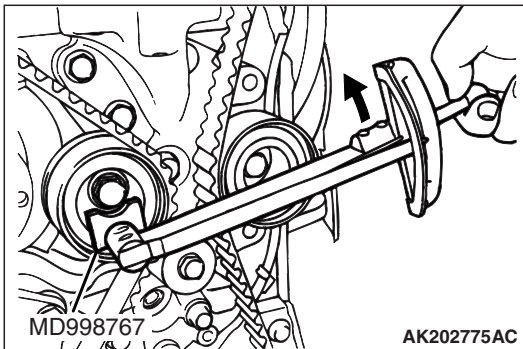

15. Loosen the tensioner pulley lock bolt.
16. Turn the torque wrench attached to the special tool MD998767 counterclockwise until the slack in the timing belt is taken up.
17. Turn the torque wrench clockwise from the position of step 16 until the torque wrench reading becomes 3.5 N·m (31 in·lb), then tighten the tensioner pulley lock bolt.

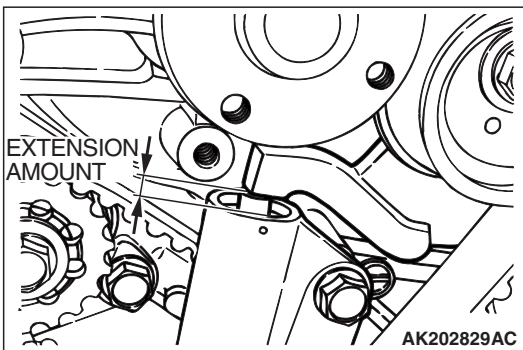

18. Remove the special tool that was installed in step 14.
19. Turn the crankshaft clockwise two turns, then let it alone for approx. 15 minutes.
20. Check that the wire (inserted in the auto-tensioner when it was installed) can be moved freely. If the wire can be pulled freely, the belt tensioner is adjusted properly. Remove the wire. Check that the auto-tensioner rod extends by the specified amount.

Standard value: 3.8 – 4.5 mm (0.15 – 0.18 inch)

CAUTION

Be sure to check the tightening torque of the crankshaft bolt anytime the crankshaft has been turned counterclockwise. If the torque lower than specification, tighten the bolt to the specified torque.

21. If the wire cannot be pulled out freely, perform the steps 14 through 18 again to make the belt tension proper.

>>M<< PLUG CAP INSTALLATION

⚠ CAUTION**Do not reuse the washer.**

1. Install the washer to the plug cap.
2. Holding the hexagonal portion of the camshaft with a wrench, tighten the plug cap to the specified torque.

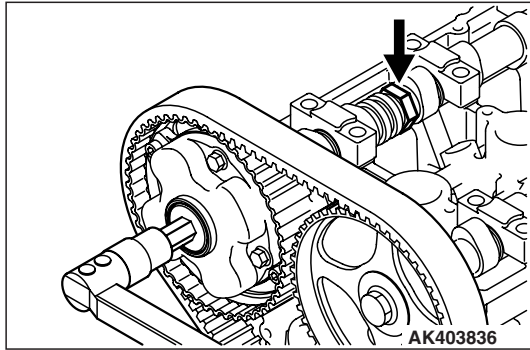
Tightening torque: 32 ± 2 N·m (24 ± 1 ft·lb)

>>N<< SEMICIRCULAR PACKING INSTALLATION

1. Remove thoroughly the old sealant remaining on the semicircular packing, cylinder head, and rocker cover.
2. Apply sealant 3M™ AAD Part number 8672 or equivalent to the surface indicated in the illustration of the semicircular packing.
3. Install the semicircular packing on the cylinder head.

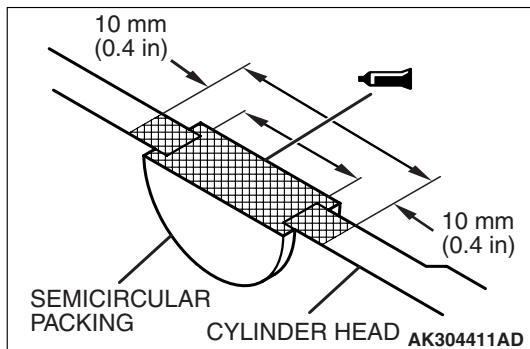
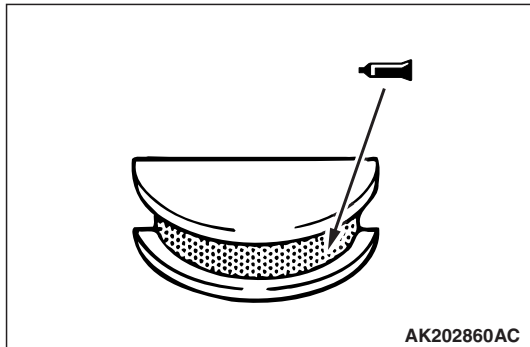

4. Apply sealant 3M™ AAD Part number 8660 or equivalent to the area indicated in the illustration of the semicircular packing and cylinder head.

>>O<< ROCKER COVER/ROCKER COVER GASKET A INSTALLATION

1. Apply beads of sealant MITSUBISHI Genuine Part number MD970389 or equivalent on the surfaces of the rocker cover indicated in the illustration.
2. Install the rocker cover gasket A on the rocker cover before the FIPG hardens.

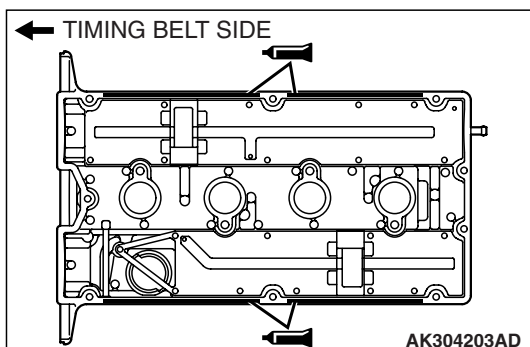

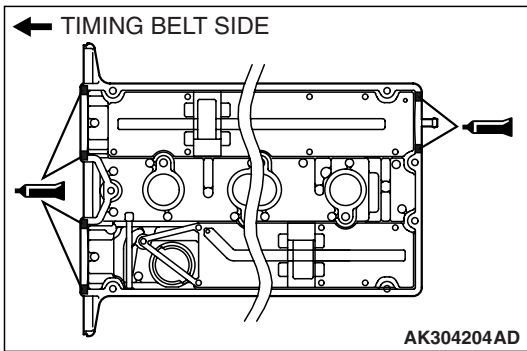

3. Apply beads of sealant MITSUBISHI Genuine Part number MD970389 or equivalent to the surfaces of the rocker cover indicated in the illustration.
4. Install the rocker cover on the cylinder head before the FIPG hardens.

INSPECTION

M1113002000340

TIMING BELT

Check the timing belt closely. Replace the belt with a new one if any of the following defects are evident:

1. Hardening of rubber backing.
Back side is glossy without resilience and leaves no indent when pressed with fingernail.

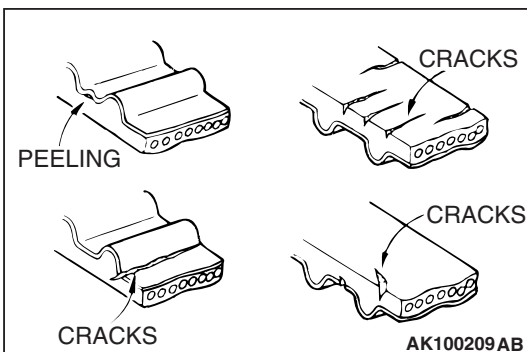
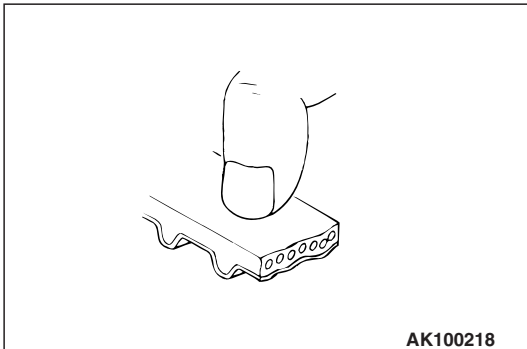

2. Surface cracks on the backing rubber.
3. Cracks or peeling of the canvas.
4. Cracks on the tooth bottom.
5. Cracks on the belt sides.

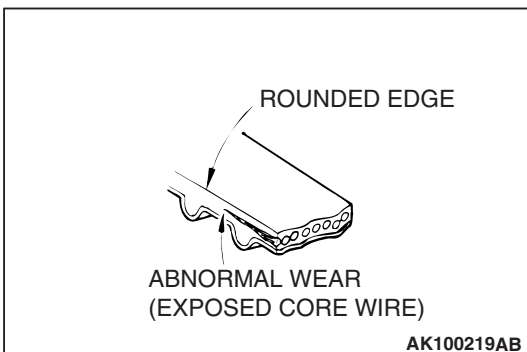

6. Abnormal wear on the belt sides.
NOTE: The sides of the belt are normal if they are sharp as if cut by a knife.

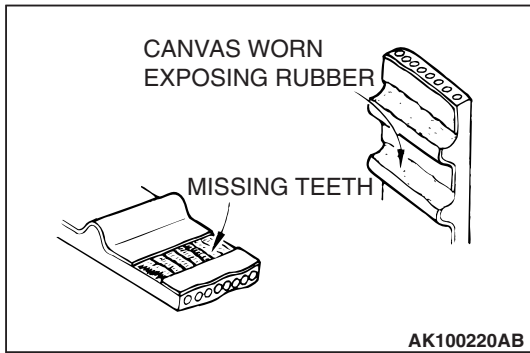

7. Abnormal wear on teeth.

Initial stage: Canvas worn (fluffy canvas fibers, rubbery texture gone, white discoloration, canvas texture indistinct)

Final stage: Canvas worn, exposing rubber (tooth width reduced)

8. Missing teeth.

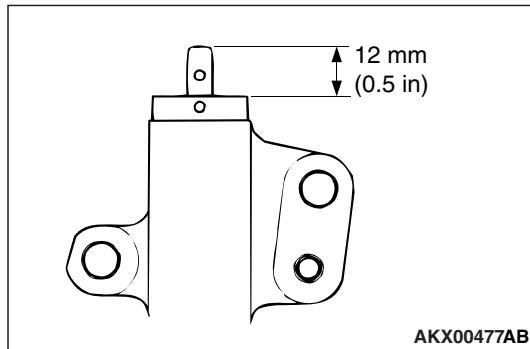

AUTO-TENSIONER

1. Check the auto-tensioner for leaks from the sealed sections.

Replace it if leaky.

2. Check the rod end for wear and other damage.

Replace the auto-tensioner if the rod is badly worn or damaged.

3. Measure the extension length of the rod.

If it is not within the standard value range, replace the auto-tensioner.

Standard value: 12 mm (0.5 inch)

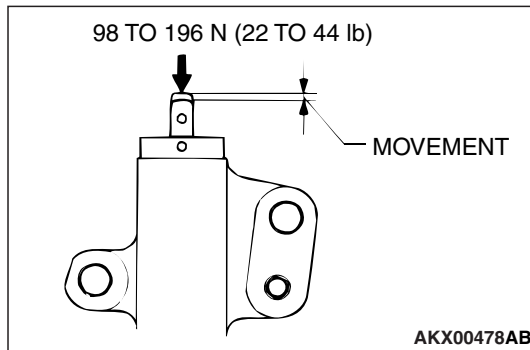

4. Press the rod with a force of 98 to 196 N (22 to 44) and measure the amount of retraction. If the measurement exceeds the standard value, replace the auto-tensioner.

Standard value: 1.0 mm (0.04 inch) or less

FUEL AND EMISSION PARTS

REMOVAL AND INSTALLATION

M1113002200333

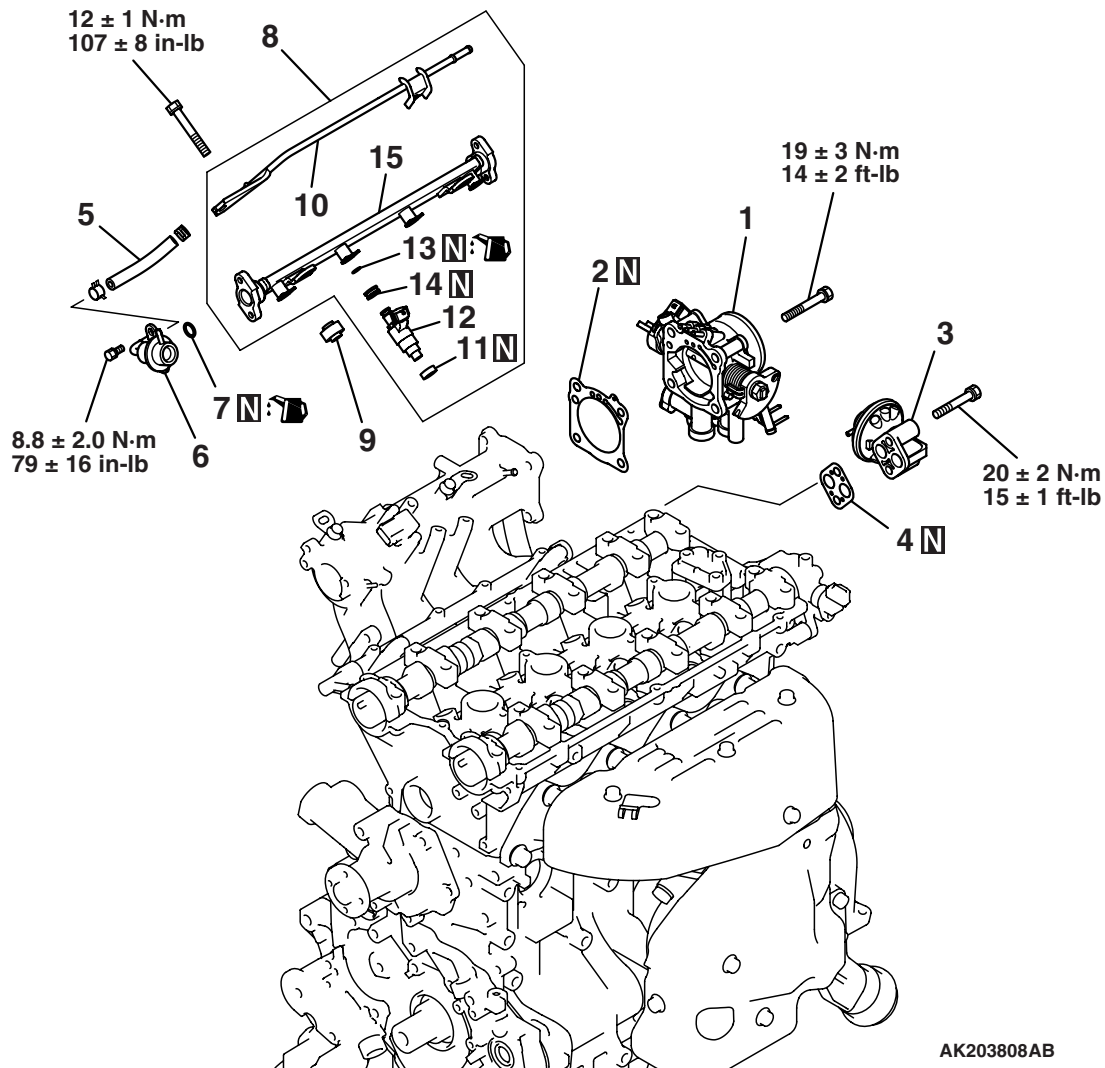

REMOVAL STEPS

1. THROTTLE BODY
- >>C<< 2. THROTTLE BODY GASKET
3. EXHAUST GAS RECIRCULATION VALVE
4. EXHAUST GAS RECIRCULATION VALVE GASKET
5. FUEL HOSE
- >>B<< 6. FUEL PRESSURE REGULATOR
7. O-RING

REMOVAL STEPS (Continued)

8. INJECTOR AND FUEL RAIL
9. INSULATOR
10. FUEL RETURN PIPE
11. INSULATOR
- >>A<< 12. INJECTOR
13. O-RING
14. GROMMET
15. FUEL RAIL

INSTALLATION SERVICE POINTS**>>A<< INJECTOR INSTALLATION**

1. Apply a thin coat of engine oil to a new O-ring.

⚠ CAUTION

Prevent engine oil from getting into the delivery pipe.

2. Insert the injector into the delivery pipe while turning it in both directions carefully not to damage the O-ring.
3. Check that the injector turns smoothly. If it does not, the O-ring may be pinched, so remove the injector and check the O-ring for damage. If the O-ring is intact, insert the injector into the delivery pipe and check it for smooth rotation again.

>>B<< FUEL PRESSURE REGULATOR INSTALLATION

1. Apply a thin coat of engine oil to a new O-ring.

⚠ CAUTION

Prevent engine oil from getting into the delivery pipe.

2. Insert the fuel pressure regulator into the delivery pipe while turning it in both directions carefully not to damage the O-ring.
3. Check that the fuel pressure regulator turns smoothly. If it does not, the O-ring may be jamming, so remove the fuel pressure regulator and check the O-ring for damage. If the O-ring is intact, insert it into the delivery pipe and check it for smooth rotation again.

>>C<< THROTTLE BODY GASKET INSTALLATION

Install the throttle body gasket with its tab located as shown in the illustration.

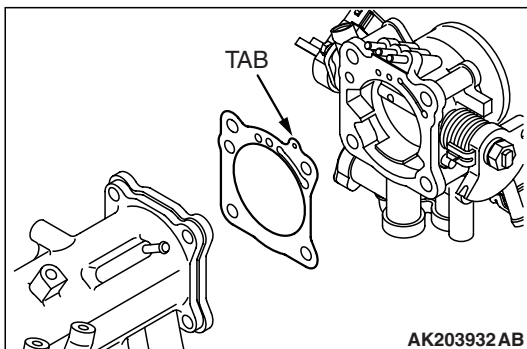

INTAKE MANIFOLD

REMOVAL AND INSTALLATION

M1113002700480

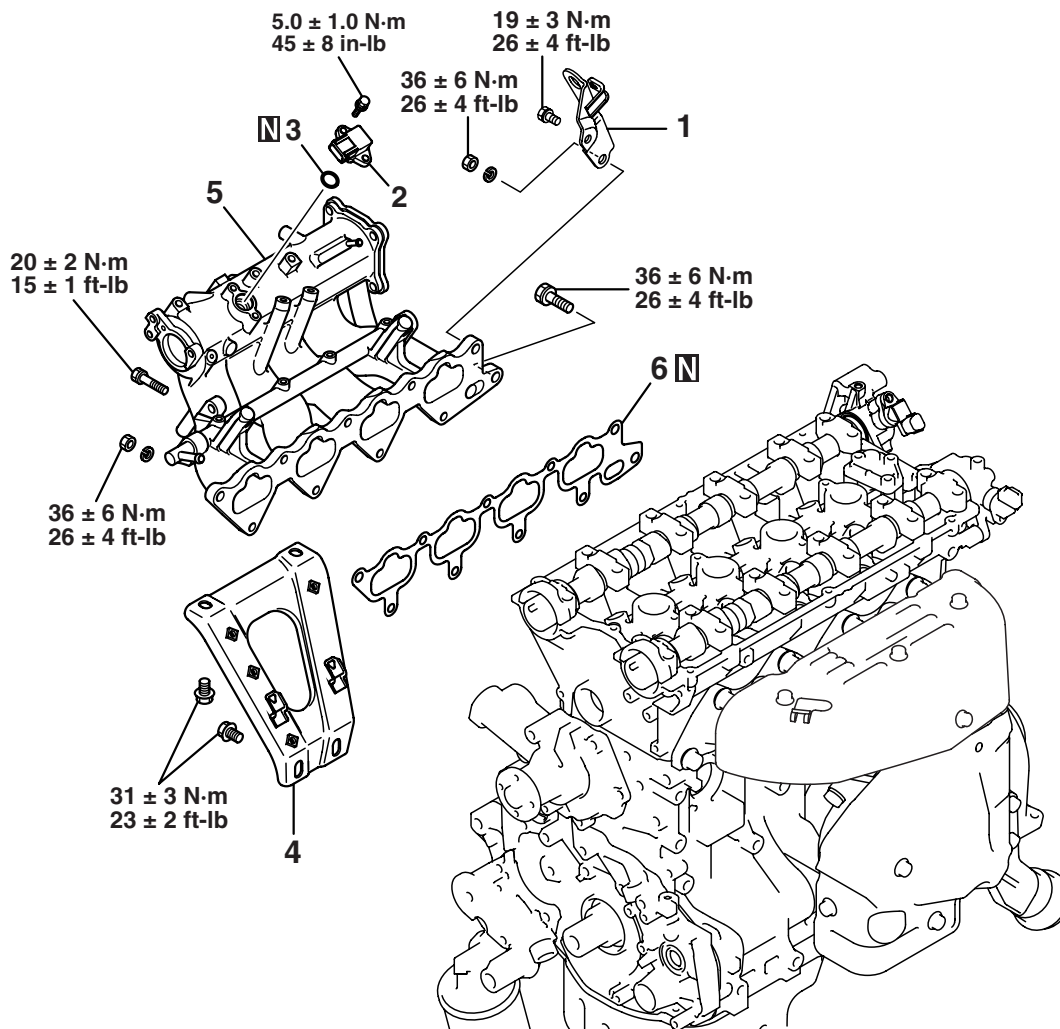

AK501893AB

REMOVAL STEPS

1. ENGINE HANGER
- >>B<<2. MANIFOLD ABSOLUTE PRESSURE SENSOR
3. O-RING

REMOVAL STEPS (Continued)

- >>A<<4. INTAKE MANIFOLD STAY
5. INTAKE MANIFOLD
6. INTAKE MANIFOLD GASKET

INSTALLATION SERVICE POINTS

>>A<< INTAKE MANIFOLD STAY INSTALLATION

Tighten the bolts to the specified torque on both ends after making sure that the stay is in close contact with the bosses on the intake manifold and cylinder block.

Tightening torque: 31 ± 3 N·m (23 ± 2 ft-lb)

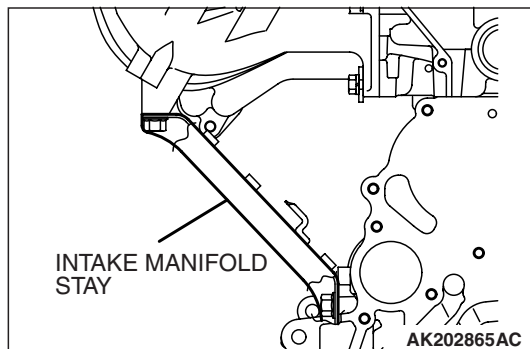
>>B<< MANIFOLD ABSOLUTE PRESSURE SENSOR
INSTALLATION**⚠ CAUTION**

- Install the manifold absolute pressure sensor carefully. Do not expose the sensor to any physical shock.
- Do not use the sensor that has fallen to floor or any other surface.

EXHAUST MANIFOLD

REMOVAL AND INSTALLATION

M1113004901018

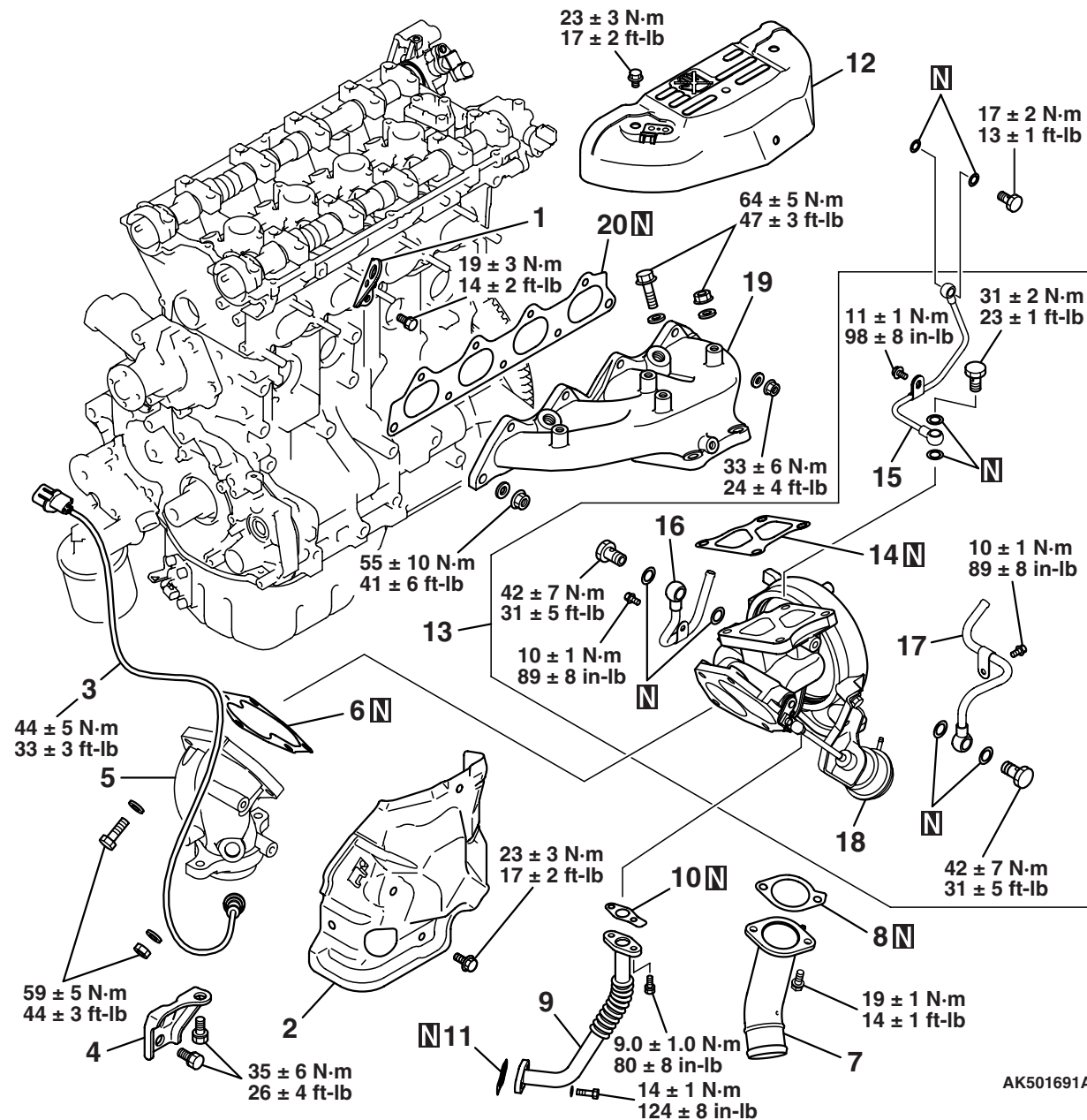

AK501691AC

REMOVAL STEPS

1. ENGINE HANGER
2. TURBOCHARGER HEAT PROTECTOR
3. OXYGEN SENSOR
4. EXHAUST FITTING BRACKET
5. EXHAUST FITTING
6. EXHAUST FITTING GASKET
7. AIR OUTLET FITTING
- >>C<< 8. AIR OUTLET FITTING GASKET
9. OIL RETURN PIPE
10. OIL RETURN PIPE GASKET
- >>B<< 11. OIL RETURN PIPE GASKET

REMOVAL STEPS (Continued)

12. EXHAUST MANIFOLD HEAT PROTECTOR
13. TURBOCHARGER ASSEMBLY AND PIPE ASSEMBLY
14. TURBOCHARGER GASKET
15. OIL PIPE
16. WATER PIPE B
17. WATER PIPE A
18. TURBOCHARGER ASSEMBLY
- >>A<< 19. EXHAUST MANIFOLD
20. EXHAUST MANIFOLD GASKET

INSTALLATION SERVICE POINT**>>A<< EXHAUST MANIFOLD INSTALLATION**

1. Hand tighten all the exhaust manifold mounting nuts.
2. Tighten the M8 nuts to 29 ± 3 N·m (21 ± 2 ft-lb) in the indicated sequence.
3. Tighten the M10 nuts to 49 ± 5 N·m (36 ± 3 ft-lb) in the indicated sequence.
4. Tighten the M8 nuts again to 29 ± 3 N·m (21 ± 2 ft-lb) in the indicated sequence.
5. Finally tighten the M10 nuts and the M8 nuts to the specified torque, both in the indicated sequence.

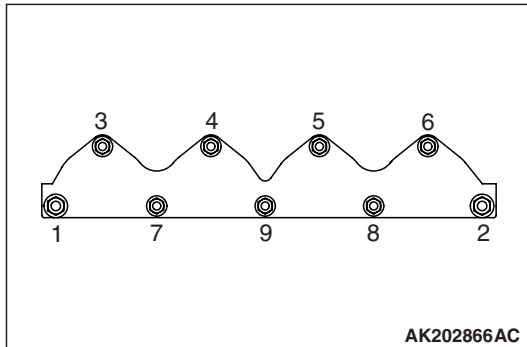
**Tightening torque:****M8: 33 ± 6 N·m (24 ± 4 ft-lb)****M10: 55 ± 10 N·m (41 ± 6 ft-lb)****>>B<< OIL RETURN PIPE GASKET INSTALLATION**

Install the oil return pipe gasket with its tab located as shown in the illustration.

NOTE: The gasket on the turbocharger end of the pipe does not require special alignment for installation.

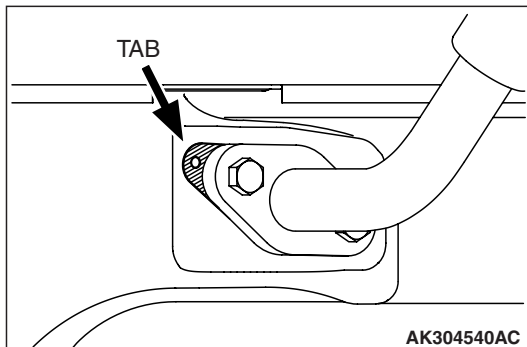
**>>C<< AIR OUTLET FITTING GASKET INSTALLATION**

Install the air outlet fitting gasket with its tab located as shown in the illustration.

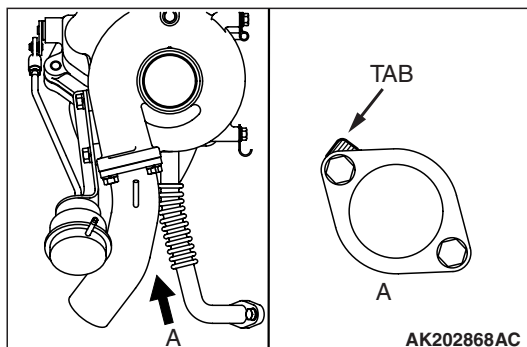

WATER PUMP & WATER HOSE

REMOVAL AND INSTALLATION

M1113017900509

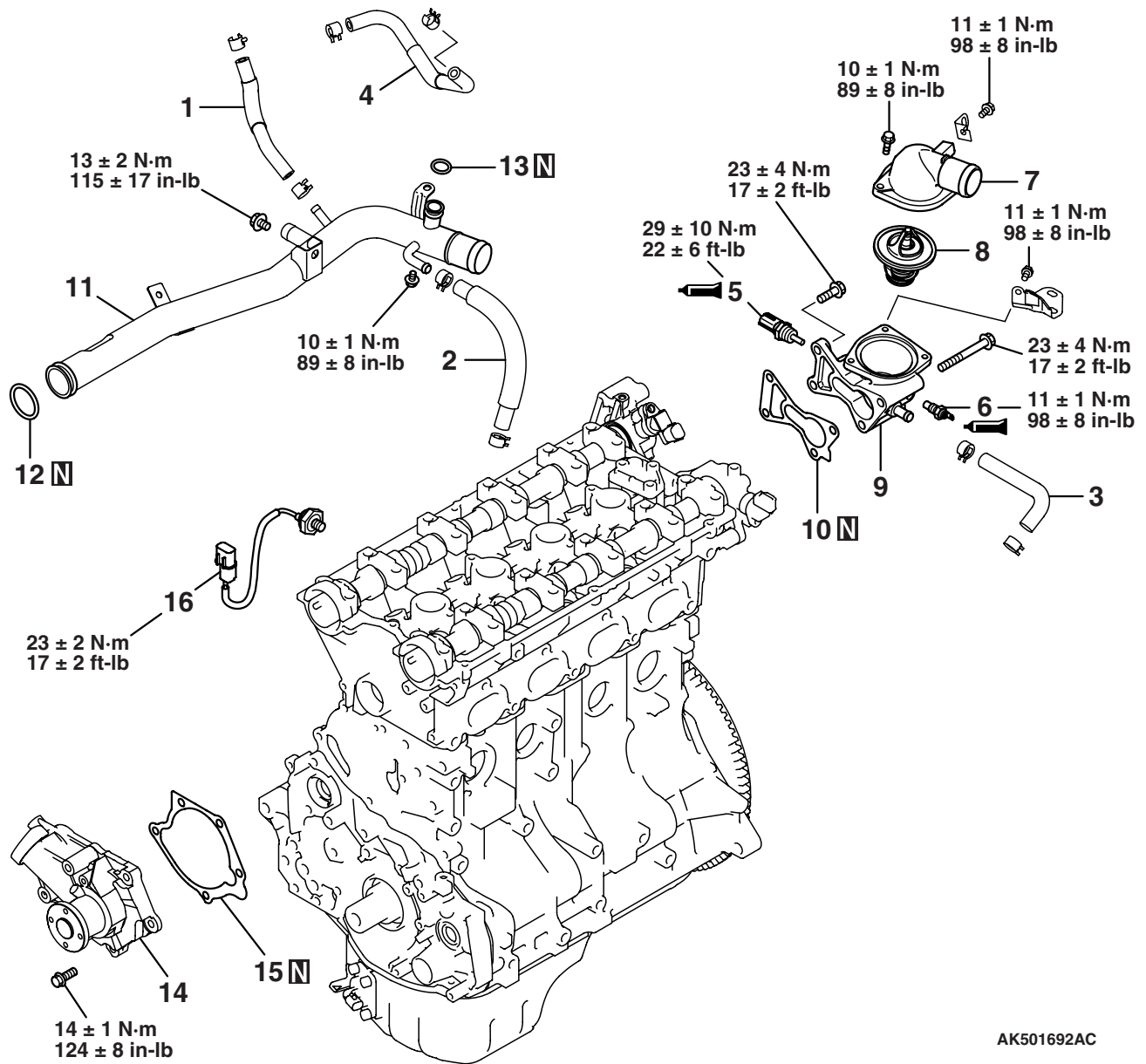

AK501692AC

REMOVAL STEPS

1. WATER HOSE
2. WATER HOSE
3. WATER HOSE
4. WATER HOSE
- >>C<< 5. ENGINE COOLANT TEMPERATURE SENSOR
- >>B<< 6. ENGINE COOLANT TEMPERATURE GAUGE UNIT
7. WATER OUTLET FITTING

REMOVAL STEPS (Continued)

8. THERMOSTAT
9. THERMOSTAT HOUSING
10. THERMOSTAT HOUSING GASKET
- >>A<< 11. WATER INLET PIPE
- >>A<< 12. O-RING
- >>A<< 13. O-RING
14. WATER PUMP
15. WATER PUMP GASKET
16. KNOCK SENSOR

INSTALLATION SERVICE POINTS**>>A<< WATER INLET PIPE / O-RING INSTALLATION****⚠ CAUTION**

- Never apply any oil or grease to the O-ring.
- Secure the water inlet pipe after the thermostat housing has been installed.

Replace the O-rings at both ends of the water inlet pipe with new ones. Insert the O-rings into the water pump and thermostat housing after wetting their peripheries with water.

>>B<< ENGINE COOLANT TEMPERATURE GAUGE UNIT INSTALLATION

1. When reusing the gauge unit, clean its thread.
2. Apply 3M™ AAD Part number 8672 or equivalent to the engine coolant temperature gauge unit.

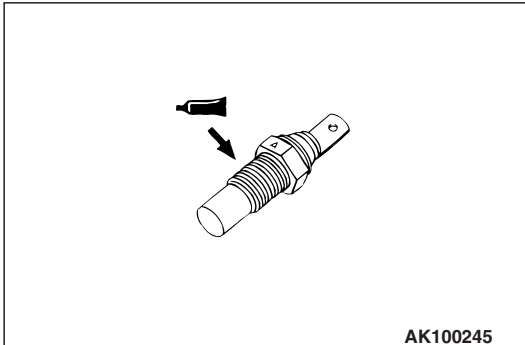
**>>C<< ENGINE COOLANT TEMPERATURE SENSOR INSTALLATION**

1. When reusing the sensor, clean its thread.
2. Apply 3M™ AAD Part number 8731 or equivalent to the engine coolant temperature sensor.

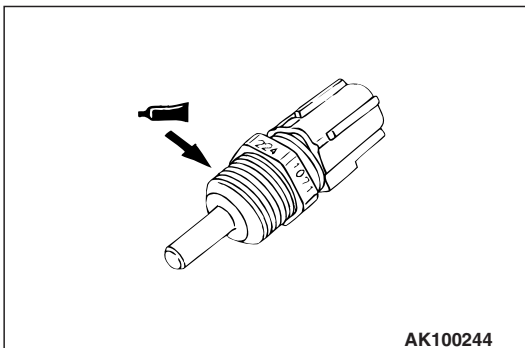

ROCKER ARMS AND CAMSHAFT

REMOVAL AND INSTALLATION

M1113005401180

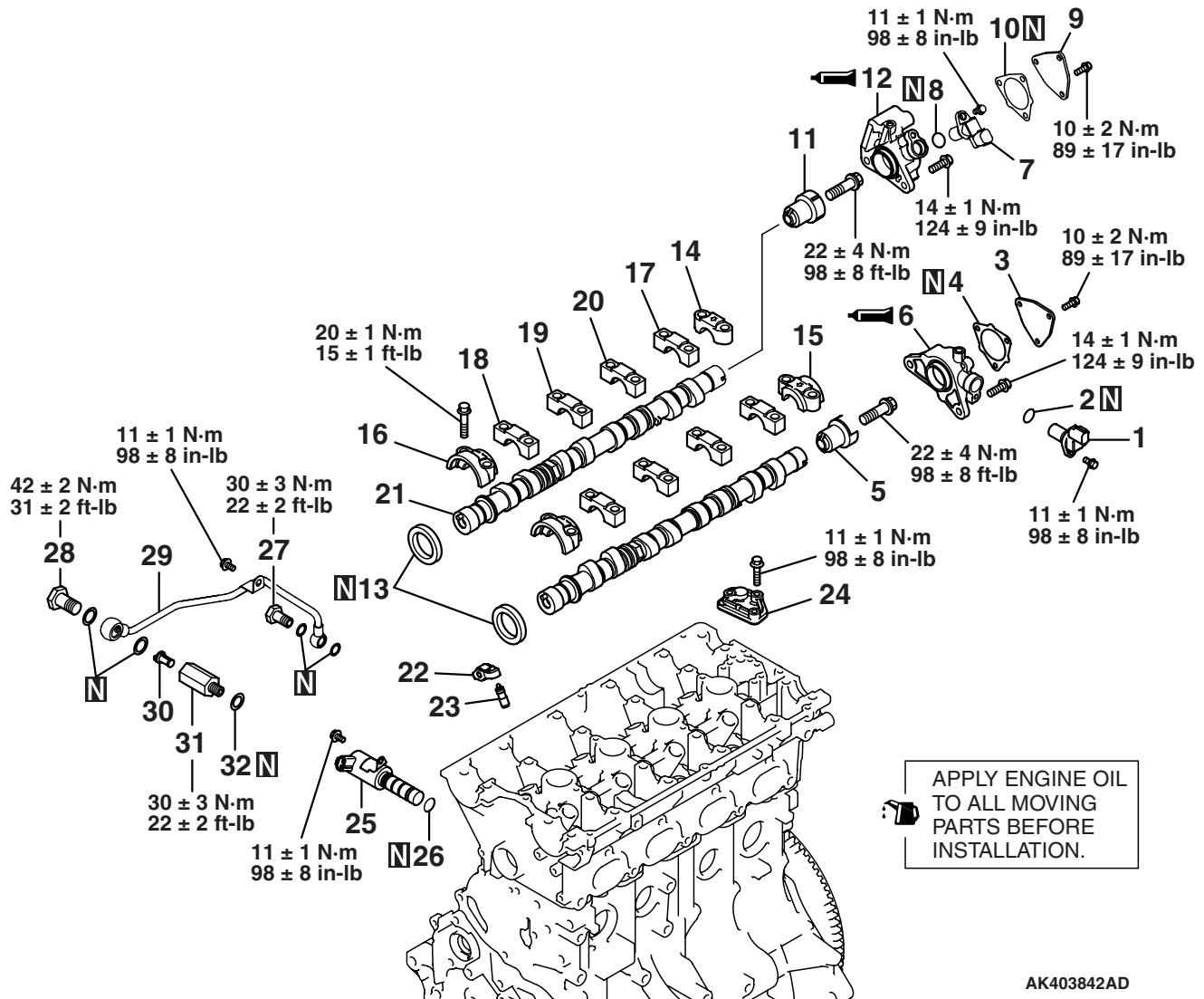

AK403842AD

REMOVAL STEPS

- >>J<< 1. CAMSHAFT POSITION SENSOR
- 2. O-RING
- >>I<< 3. COVER
- >>I<< 4. GASKET
- >>H<< 5. CAMSHAFT POSITION SENSING CYLINDER
- >>G<< 6. CAMSHAFT POSITION SENSOR SUPPORT
- >>J<< 7. CAMSHAFT POSITION SENSOR
- 8. O-RING
- >>I<< 9. COVER
- >>I<< 10. GASKET
- >>H<< 11. CAMSHAFT POSITION SENSING CYLINDER
- >>G<< 12. CAMSHAFT POSITION SENSOR SUPPORT
- >>F<< 13. CAMSHAFT OIL SEAL
- >>E<< 14. BEARING CAP, REAR RIGHT

REMOVAL STEPS (Continued)

- >>E<< 15. BEARING CAP, REAR LEFT
- >>E<< 16. BEARING CAP, FRONT
- >>E<< 17. BEARING CAP NO.5
- >>E<< 18. BEARING CAP NO.2
- >>E<< 19. BEARING CAP NO.3
- >>E<< 20. BEARING CAP NO.4
- >>D<< 21. CAMSHAFT
- 22. ROCKER ARM
- <<A>> >>C<< 23. LASH ADJUSTER
- 24. OIL DELIVERY BODY
- 25. OIL FEEDER CONTROL VALVE
- 26. O-RING
- 27. CHECK VALVE
- >>B<< 28. EYE BOLT
- 29. OIL PIPE
- >>A<< 30. OIL FEEDER CONTROL VALVE FILTER
- 31. OIL PIPE JOINT
- 32. GASKET

Required Special Tools:

- MD998442: Air Bleed Wire
- MD998713: Camshaft Oil Seal Installer

REMOVAL SERVICE POINT**<<A>> LASH ADJUSTER REMOVAL****⚠ CAUTION**

When reusing a lash adjuster, it must be washed and inspected before installation. (Refer to [P.11B-39](#))

INSTALLATION SERVICE POINTS**>>A<< OIL FEEDER CONTROL VALVE FILTER INSTALLATION****⚠ CAUTION**

Install the oil feeder control valve filter on which no foreign materials, no defects and no deformation are confirmed.

>>B<< EYE BOLT INSTALLATION

Holding the oil pipe joint with a spanner, tighten the eye bolt to the specified torque.

Tightening torque: $42 \pm 2 \text{ N} \cdot \text{m}$ ($31 \pm 2 \text{ ft} \cdot \text{lb}$)

NOTE: When the oil pipe joint is rotated together with the eye bolt at the installation, the oil pump would be possibly damaged.

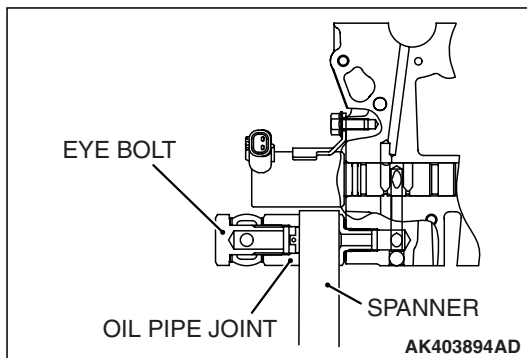
**>>C<< LASH ADJUSTER INSTALLATION****⚠ CAUTION**

When reusing a lash adjuster, it must be washed and inspected before installation. (Refer to [P.11B-39](#))

Install the lash adjuster into the rocker arm, being careful not to spill the diesel fuel it contains.

>>D<< CAMSHAFT INSTALLATION**⚠ CAUTION**

- Do not confuse the intake camshaft with the exhaust camshaft.
- As shown in the illustration, the shapes of the intake camshaft and the exhaust camshaft are different.

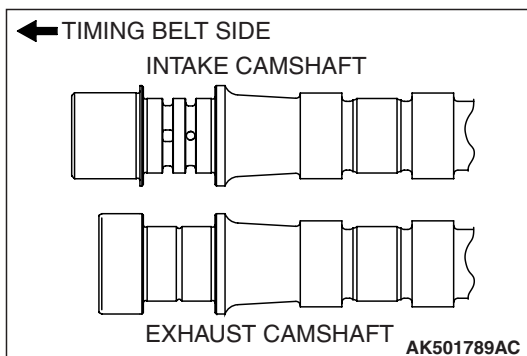

>>E<< BEARING CAP INSTALLATION

1. Set each camshaft with its dowel pin at the top.

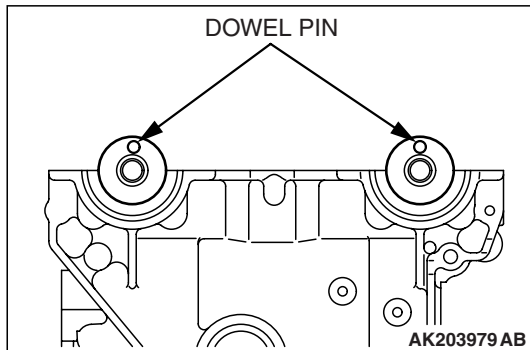

2. The bearing caps Nos. 2 –5 are identical in shape for both intake and exhaust camshafts. Check the identification mark on each cap before installation.

Identification mark (stamped on front and Nos. 2 – 5 bearing caps)

I: intake side

E: exhaust side

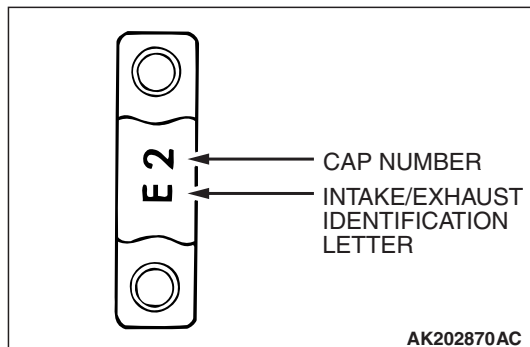

3. Remove completely any sealant remaining on the bearing caps and cylinder head.

4. Apply sealant (MITSUBISHI Genuine Part number MD970389 or equivalent) to the surfaces indicated in the illustration.

5. Install each bearing cap and tighten its bolts in two or three passes.

6. Finally, tighten the bolts to the specified torque.

Tightening torque: 20 ± 1 N·m (15 ± 1 ft-lb)

7. Check that the rocker arms are correctly installed.

NOTE: Wipe off any squeezed out sealant completely.

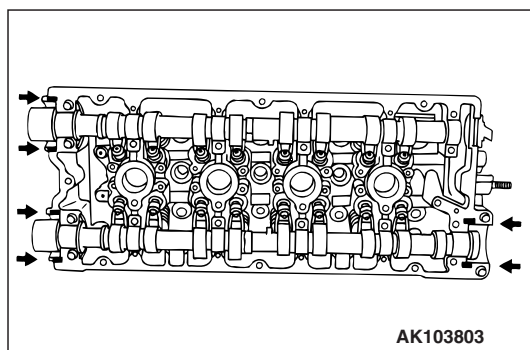

>>F<< CAMSHAFT OIL SEAL INSTALLATION

Use the special tool MD998713 to drive each oil seal into position in the cylinder head.

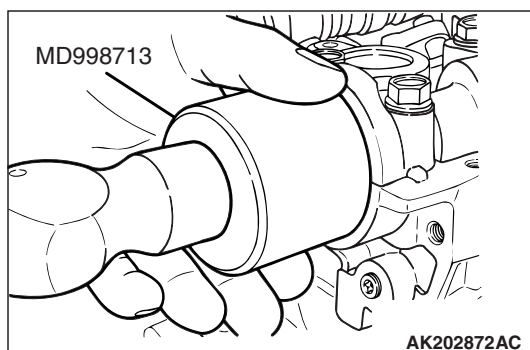

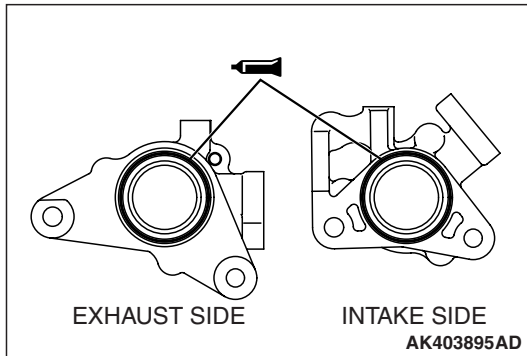

>>G<< CAMSHAFT POSITION SENSOR SUPPORT INSTALLATION

1. Remove completely the FIPG remaining on the camshaft position sensor support and cylinder head.
2. Apply a 3 ± 1 mm diameter bead of FIPG to the indicated surface of the camshaft position sensor support.

Specified sealant:

Mitsubishi Genuine Part No.MD970389 or equivalent

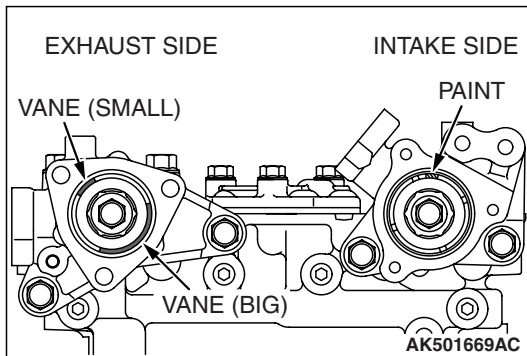

>>H<< CAMSHAFT POSITION SENSING CYLINDER INSTALLATION

1. Turn the exhaust camshaft to the No.1 cylinder top dead centre position.
NOTE: The camshaft will slightly turn counterclockwise by the force of the exhaust valve spring.
2. Install the camshaft position sensing cylinder with the vanes and paint located as shown in the drawing.

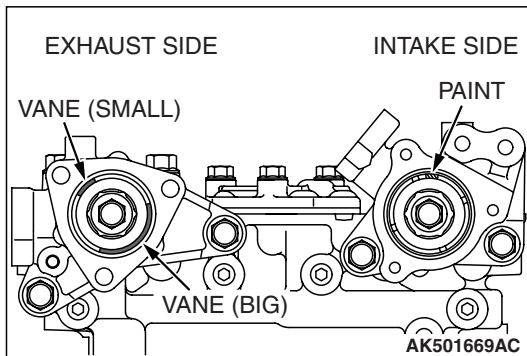

>>I<< COVER / GASKET INSTALLATION

1. Before the cover and the gasket installations, confirm the vanes and paint of the every sensing cylinder are in position indicated in the illustration with the camshaft on No.1 top dead center of compression stroke.

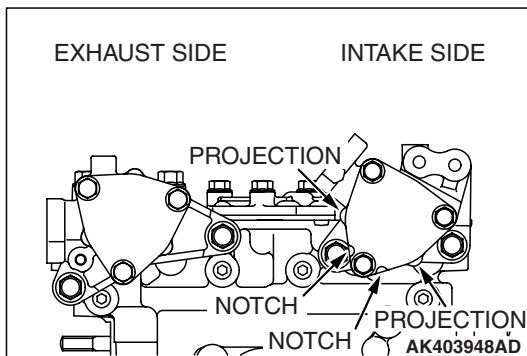

2. At the intake side, install the cover notch and the gasket projection in position indicated in the illustration, and then tighten them to the specified torque.
At the exhaust side, the cover and the gasket do not have the specified direction or angle of the installation.

Tightening torque: 14 ± 1 N·m (124 ± 9 in-lb)

NOTE: The cover and the gasket have no difference between the front and the reverse sides.

>>J<< CAMSHAFT POSITION SENSOR INSTALLATION

Install the camshaft position sensor with paying attention to the installation direction because an identification paint is not applied to the camshaft position sensor at the intake side.

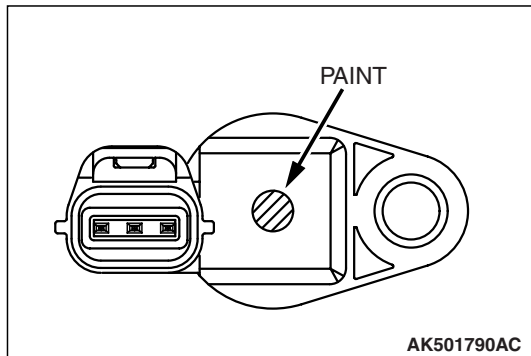

INSPECTION

M1113005500980

CAMSHAFT

Measure the cam height and replace the camshaft if any height exceeds the specified limit.

Standard value:

Intake: 35.96 mm (1.42 inches)

Exhaust: 35.49 mm (1.40 inches)

Limit:

Intake: 35.46 mm (1.40 inches)

Exhaust: 34.99 mm (1.38 inches)

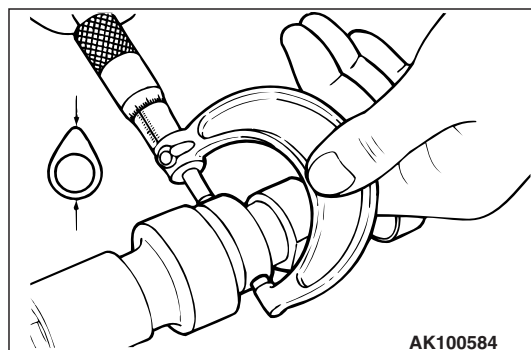

LASH ADJUSTERS

⚠ CAUTION

- The lash adjuster is a precision-engineered component. Do not allow dust or other foreign matter to enter it.
- Do not disassemble lash adjusters.
- Use only non-contaminated diesel fuel to clean the lash adjuster.

1. Prepare three containers and approximately five liters of diesel fuel. Pour into each container the diesel fuel in an amount enough for a lash adjuster placed in the container in its upright position to completely submerge.

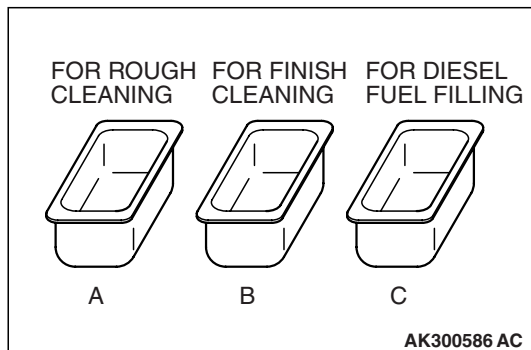

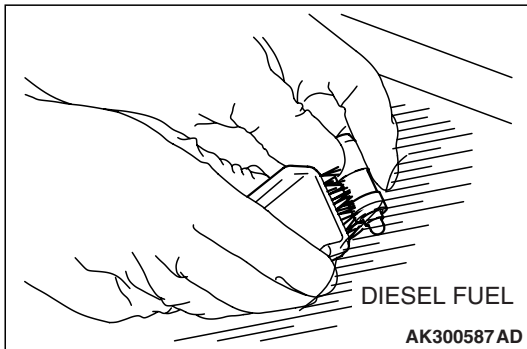

- Place the lash adjuster in container A and wash its outside surface.

NOTE: Use a nylon brush if there are hard-to-remove deposits.

CAUTION

The steel ball spring of the lash adjuster is extremely weak. The lash adjuster's functionality may be badly affected if the special tool is inserted too strongly.

- While gently pushing the internal steel ball using the special tool MD998442, move the plunger in and out 5 –10 times to eliminate stiffness in the plunger and expel contaminated oil.

NOTE: The plunger must be free from jamming and any other abnormalities. If a defect is found in plunger operation, replace the lash adjuster.

CAUTION

The hole in the side of the lash adjuster must be directed toward the inside of container A. Never direct it toward any person.

- Take the lash adjuster out of the container, then move the plunger by pushing the steel ball gently to discharge the diesel fuel from the pressure chamber.

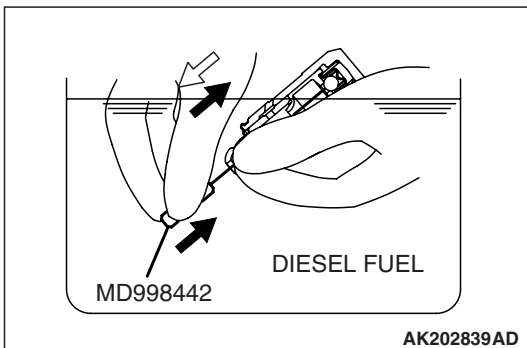
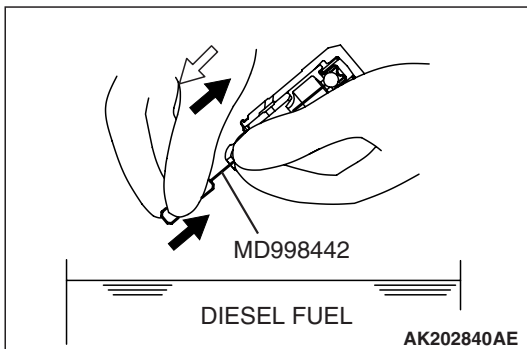
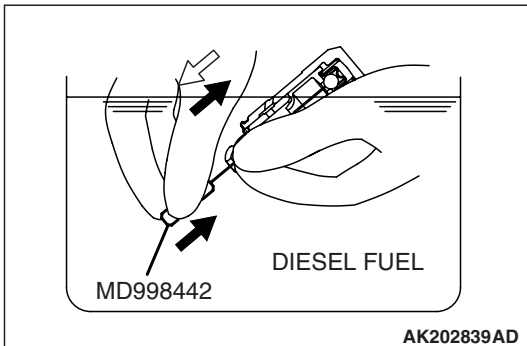

CAUTION

The steel ball spring of the lash adjuster is extremely weak. The lash adjuster's functionality may be badly affected if the special tool is inserted too strongly.

- Soak the lash adjuster in the diesel fuel in container B. Move the plunger in and out 5 –10 times by gently pushing the internal steel ball using the special tool MD998442 until the plunger moves smoothly to wash the lash adjuster's pressure chamber.

CAUTION

The hole in the side of the lash adjuster must be directed toward the inside of container B. Never direct it toward any person.

- Take the lash adjuster out of the container, then move the plunger by pushing the steel ball gently to discharge the diesel fuel from the pressure chamber.

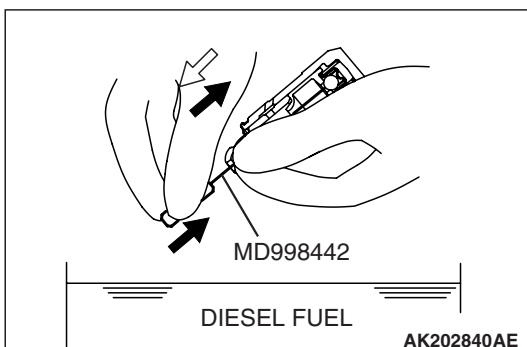

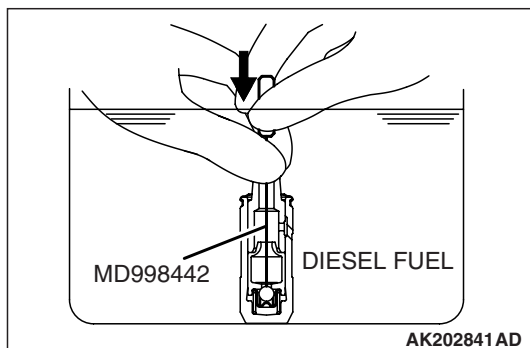

CAUTION

Do not use container C for cleaning. If cleaning is performed in container C, foreign matter could enter the pressure chamber when the chamber is filled with diesel fuel.

7. Soak the lash adjuster in the diesel fuel in container C. Gently push the internal steel ball using the special tool MD998442.

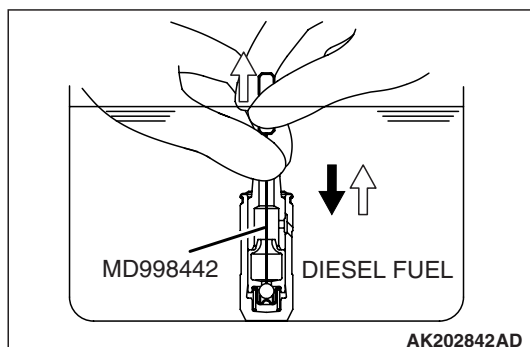

8. Place the lash adjuster upright with the plunger at the top. Push the plunger firmly until it makes a full stroke, then return the plunger slowly and release the hold of the steel ball to allow the pressure chamber to be filled with diesel fuel.

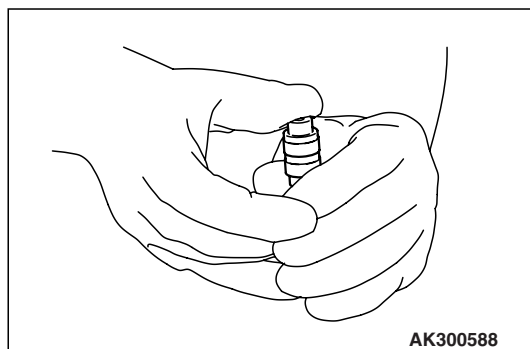

9. Take the lash adjuster out of the container, place it upright with the plunger at the top, and push the plunger firmly. The plunger must not move at all.

NOTE: If the lash adjuster contracts, perform the operations 7 through 9 again. Replace the lash adjuster if it still contracts even after the pressure chamber has completely been filled with diesel fuel (air has been bled).

10. Keep the serviced lash adjusters in their upright positions to prevent diesel fuel from spilling out. Protect them from dust or other foreign matter. Install the lash adjusters onto the engine as soon as possible.

CYLINDER HEAD AND VALVES

REMOVAL AND INSTALLATION

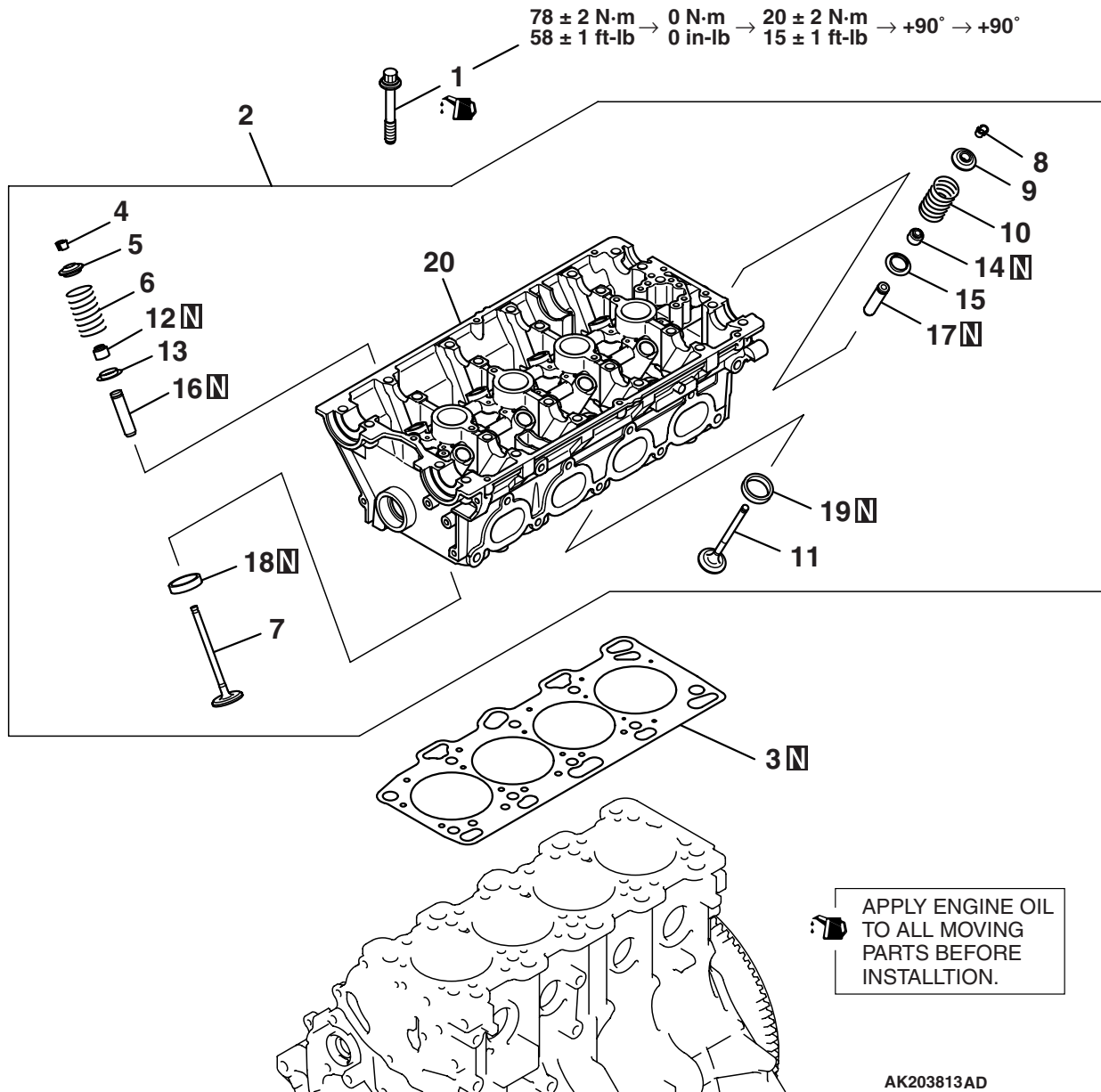

REMOVAL STEPS

- <<A>> >>D<< 1. CYLINDER HEAD BOLT
- 2. CYLINDER HEAD ASSEMBLY
- 3. CYLINDER HEAD GASKET
- <> >>C<< 4. RETAINER LOCK
- 5. VALVE SPRING RETAINER
- >>B<< 6. VALVE SPRING
- 7. INTAKE VALVE
- <> >>C<< 8. RETAINER LOCK
- 9. VALVE SPRING RETAINER
- >>B<< 10. VALVE SPRING

REMOVAL STEPS (Continued)

- <<D>> 11. EXHAUST VALVE
- <<C>> >>A<< 12. VALVE STEM SEAL
- 13. VALVE SPRING SEAT
- <<C>> >>A<< 14. VALVE STEM SEAL
- 15. VALVE SPRING SEAT
- 16. INTAKE VALVE GUIDE
- 17. EXHAUST VALVE GUIDE
- 18. INTAKE VALVE SEAT
- 19. EXHAUST VALVE SEAT
- 20. CYLINDER HEAD

Required Special Tools:

- MB991654: Cylinder Head Bolt Wrench (12)
- MD998735: Valve Spring Compressor
- MD998737: Valve Stem Seal Installer
- MD998772: Valve Spring Compressor

REMOVAL SERVICE POINTS

<<A>> CYLINDER HEAD BOLT REMOVAL

Using the special tool MB991653 to loosen the cylinder head bolts.

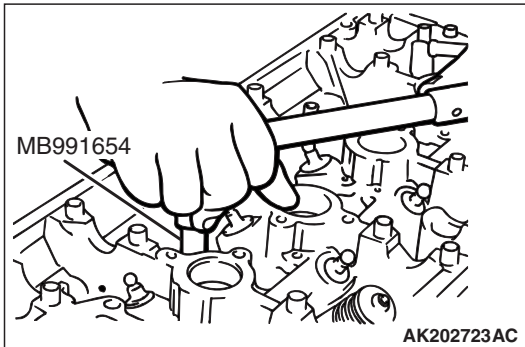

<> RETAINER LOCK REMOVAL

1. Using special tool MD998735 or MD998772, compress the retainer locks.
2. Remove the retainer locks.

NOTE: Tag removed valves, springs and other components, noting their cylinder numbers and locations to facilitate reassembly. Store these components safely.

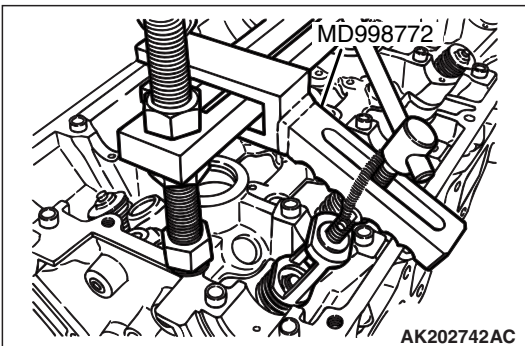
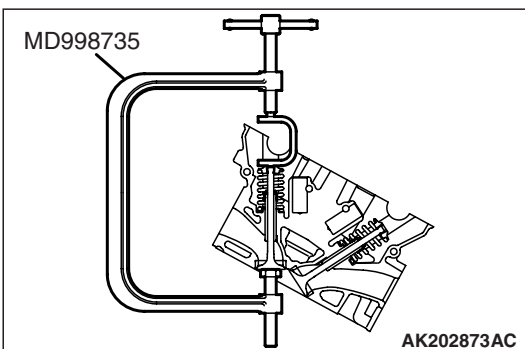

<<C>> VALVE STEM SEAL REMOVAL

Do not reuse removed valve stem seal.

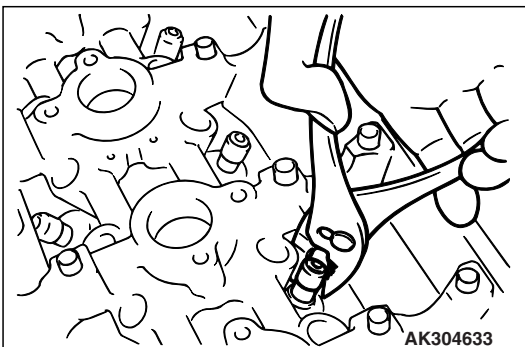

<<D>> VALVE HANDLING PRECAUTIONS

⚠ WARNING

Sodium reacts violently with water or moisture generating heat and liberating hydrogen. It must be handled with utmost care because otherwise the following dangerous conditions may result:

- ***Loss of eyesight if sodium gets in eyes.***
- ***Burns if sodium contact skin.***
- ***Fire hazard.***

1. Handling of Sodium-filled Exhaust Valves

- (1) Sodium-filled exhaust valves are not dangerous and may be handled in the same way as ordinary valves unless they are broken.
- (2) Never try to break the valves and expose sodium to the air.
- (3) When worn exhaust valves are to be discarded, have them disposed of by a salvage company equipped with special disposal system, notifying them that the valves contain sodium.
- (4) Should the exhaust valves be broken, neutralize sodium using the method described below, and discard the valves in the same way as ordinary valves.

⚠ CAUTION

- **Do not let the solution contact the eyes or the skin.**
- **Should it get in the eyes, immediately flush them with clean water thoroughly, and receive medical attention. When it contacts the skin, wash with ample amounts of clean water.**

2. How to Neutralize Sodium

- (1) Place a container filled with more than 10 liters (10.6 qt) of water in a well ventilated large space.
- (2) Wear rubber gloves and goggles, and carefully take out broken valves from the cylinder head.

⚠ CAUTION

- **Valves must be neutralized one at a time.**
 - **Put a valve in the container only after sodium in the preceding one has completely reacted with water.**
- (3) Put a broken valves in the water-filled container and quickly get away from the container at least 2 or 3 m (6.6 or 9.8 ft)
 - (4) Keep fire away from the container during the neutralization. The resulting hydrogen gas is highly explosive.

NOTE: The reaction occurs when water enters the cavity in the valve. Hydrogen gas may be trapped inside the valve, temporarily blocking the water passage. In such a case, wait until hydrogen gas is released and remaining sodium reacts with water.

- (5) After the neutralization of sodium, water in the container contains sodium hydroxide and is highly alkaline. The water solution should be disposed of according to local regulations.

INSTALLATION SERVICE POINTS

>>A<< VALVE STEM SEAL INSTALLATION

⚠ CAUTION

- Do not reuse removed valve stem seals.

1. Install the valve spring seat.

NOTE: Do not confuse the stem seals for intake valves with those for exhaust valves.

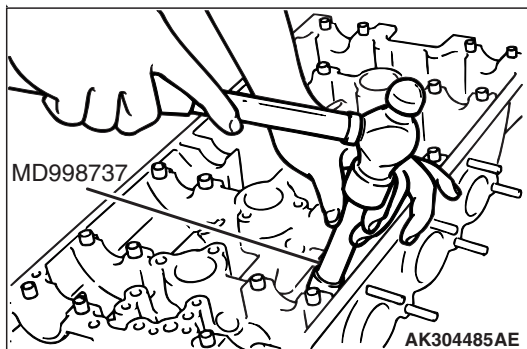
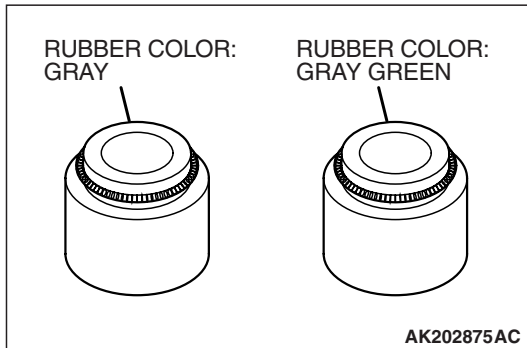

⚠ CAUTION

- The valve stem seal must be installed using the correct special tool. Incorrect installation could result in oil leaking past the valve guide.
2. Using special tool MD998737, install a new stem seal to the valve guide.

>>B<< VALVE SPRING INSTALLATION

Install the valve spring so that the painted end is on the rocker arm side.

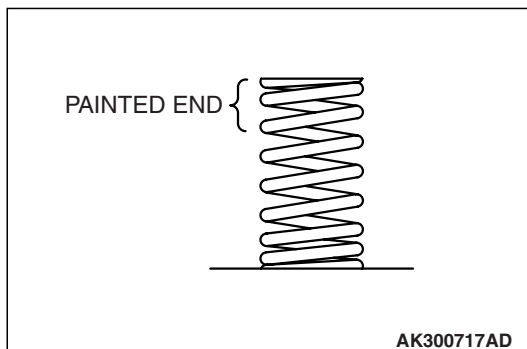

>>C<< RETAINER LOCK INSTALLATION

Using special tool MD998735 or MD998772, compress the valve spring and insert the retainer lock into position.

NOTE: The valve spring, if excessively compressed, causes the bottom end of retainer to be in contact with the stem seal, and damage it.

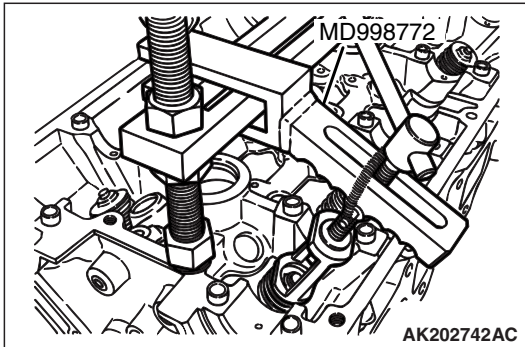
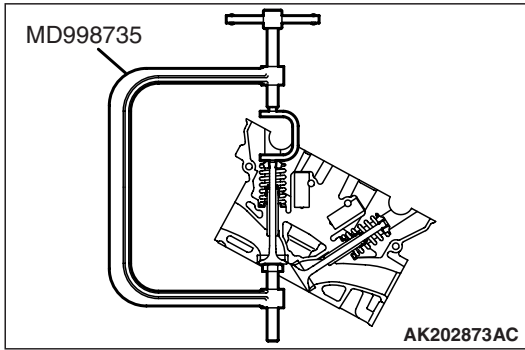
**>>D<< CYLINDER HEAD BOLT INSTALLATION**

1. When the removed cylinder head bolts are to be reused, check that the shank length of each bolt meets the limit. If it exceeds the limit, replace the bolts.

Limit: 99.4 mm (3.91 inches)

2. Apply engine oil to the thread of the bolts and to the washers.

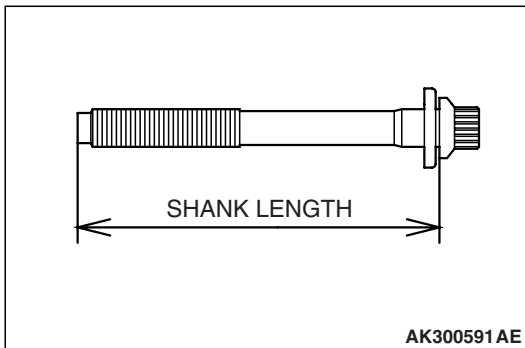

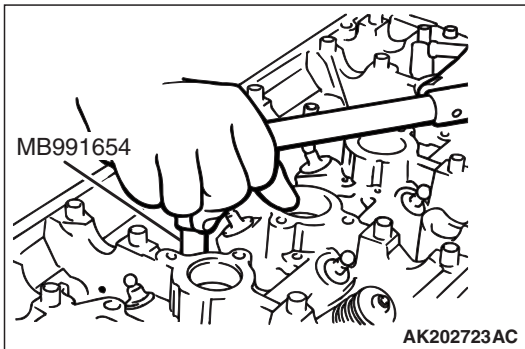

3. Using special tool MB991654 tighten the bolts to the specified torque $78 \pm 2 \text{ N} \cdot \text{m}$ ($58 \pm 1 \text{ ft-lb}$), using the tightening sequence shown.
4. Loosen all bolts fully in the reverse order of tightening.
5. Retighten the loosened bolts to $20 \pm 2 \text{ N} \cdot \text{m}$ ($15 \pm 1 \text{ ft-lb}$) in the tightening sequence shown.

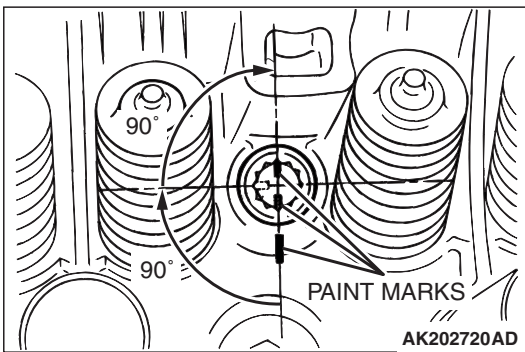
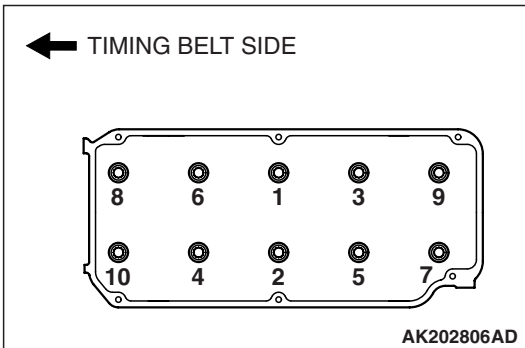

CAUTION

- If the bolt is turned less than 90 degree angle, proper fastening performance may not be achieved. Be careful to turn each bolt exactly 90 degree angle.
 - If the bolt is overtightened, loosen the bolt completely and then retighten it by repeating the tightening procedure from step 1.
6. Make a paint mark across each bolt head and cylinder head.
 7. Tighten the cylinder head bolts 90 degree angle in the specified order.
 8. Tighten the bolts another 90 degree angle in the same order as in step 7, and check that the paint marks on the cylinder head bolt are aligned with the paint marks on the cylinder head.

INSPECTION

M1113007000356

CYLINDER HEAD

1. Before cleaning the cylinder head, check it for water leaks, gas leaks, cracks, and other damage.
2. Remove all oil, water scale, sealant, and carbon. After cleaning the oil passages, blow air through them to verify that they are not blocked.
3. Check the cylinder head gasket surface for flatness by using a straight edge and feeler gauge.

Standard value: 0.05 mm (0.0020 inch)
Limit: 0.2 mm (0.008 inch)

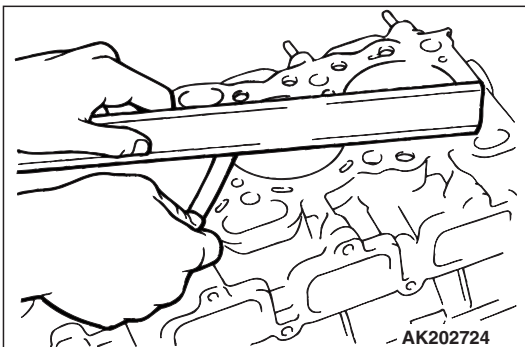

- If flatness exceeds the specified limit, grind the gasket surface to specification.

Grinding limit: *0.2 mm (0.008 inch)

***Includes/combined with cylinder block grinding**

**Cylinder head height (Specification when new):
131.9 – 132.1 mm (5.193 – 5.201 inches)**

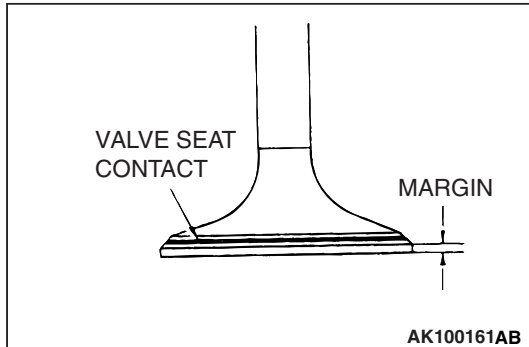

VALVE

- Check the valve face for correct contact. If contact is uneven or incomplete, reface the valve seat.
- If the margin is less than specified, replace the valve.

Standard value:

Intake: 1.0 mm (0.039 inch)

Exhaust: 1.5 mm (0.059 inch)

Limit:

Intake: 0.5 mm (0.020 inch)

Exhaust: 1.0 mm (0.039 inch)

- Measure the valve length. If the measurement is less than specified, replace the valve.

Standard value:

Intake: 109.50 mm (4.311 inches)

Exhaust: 109.70 mm (4.319 inches)

Limit:

Intake: 109.00 mm (4.291 inches)

Exhaust: 109.20 mm (4.299 inches)

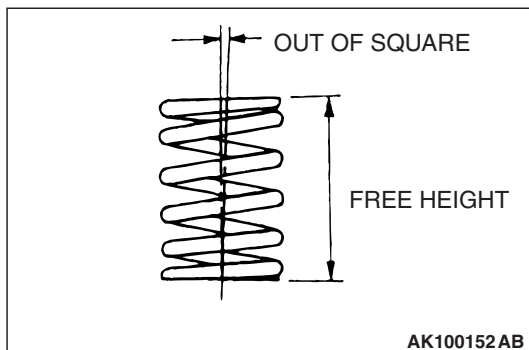

VALVE SPRING

- Measure the valve spring free height. If the measurement is less than specified, replace the spring.

Standard value: 50.4 mm (1.98 inches)

Limit: 49.4 mm (1.94 inches)

- Measure the squareness of the spring. If the measurement is less than specified, replace the spring.

Standard value: 2° or less

Limit: 4°

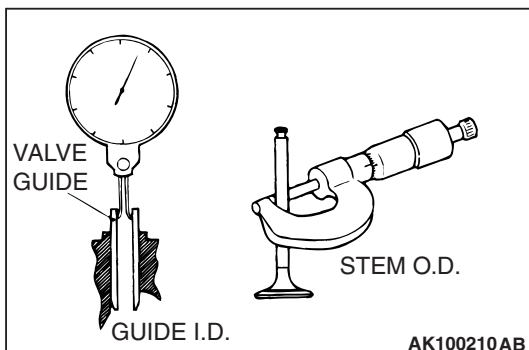

VALVE GUIDE

Measure the clearance between the valve guide and valve stem. If the clearance exceeds the specified limit, replace the valve guide or valve, or both.

Standard value:

Intake: 0.02 – 0.05 mm (0.0008 – 0.0020 inch)

Exhaust: 0.05 – 0.09 mm (0.0020 – 0.0035 inch)

Limit:

Intake: 0.10 mm (0.0039 inch)

Exhaust: 0.15 mm (0.0059 inch)

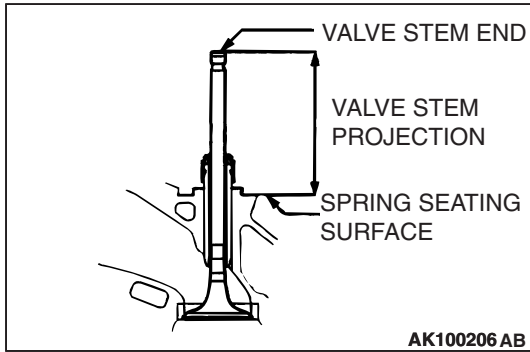

VALVE SEAT

Assemble the valve, then measure the valve stem projection between the end of the valve stem and the spring seating surface. If the measurement exceeds the specified limit, replace the valve seat.

Standard value:

Intake: 49.20 mm (1.9370 inches)

Exhaust: 48.40 mm (1.9055 inches)

Limit

Intake: 49.70 mm (1.9567 inches)

Exhaust: 48.90 mm (1.9252 inches)

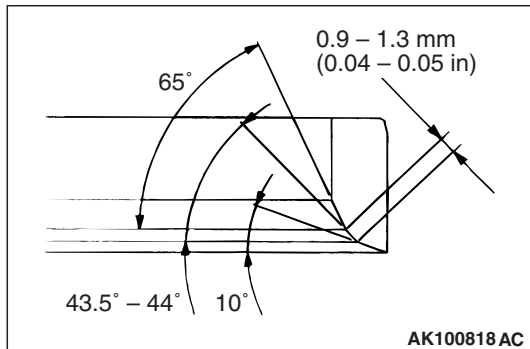

VALVE SEAT RECONDITIONING PROCEDURE

1. Before correcting the valve seat, check the clearance between the valve guide and valve. If necessary, replace the valve guide.
2. Using the appropriate special tool or seat grinder, correct the valve seat to achieve the specified seat width and angle.
3. After correcting the valve seat, lap the valve and valve seat using lapping compound. Then, check the valve stem projection (refer to VALVE SEAT in INSPECTION).

VALVE SEAT REPLACEMENT PROCEDURE

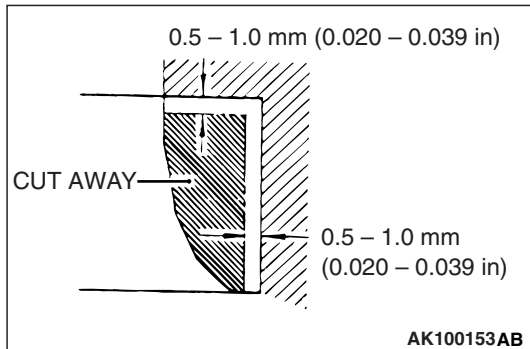

1. Cut the valve seat to be replaced from the inside to reduce the wall thickness. Then, remove the valve seat.

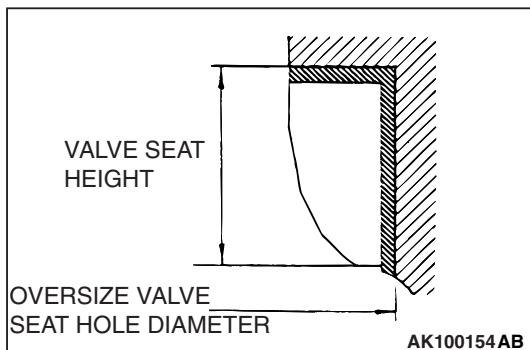

2. Rebore the valve seat hole in the cylinder head to match the selected oversize valve seat diameter.

Intake valve seat hole diameter

0.3 oversize: 35.30 – 35.33 mm (1.3898 – 1.3909 inches)

0.6 oversize: 35.60 – 35.63 mm (1.4016 – 1.4028 inches)

Exhaust valve seat hole diameter

0.3 oversize: 33.30 – 33.33 mm (1.3110 – 1.3122 inches)

0.6 oversize: 33.60 – 33.63 mm (1.3228 – 1.3240 inches)

3. Prevent galling of the cylinder head bore by cooling the valve seat with liquid nitrogen before press-fitting it.

4. Correct the valve seat to achieve the specified width and angle (refer to VALVE SEAT RECONDITIONING PROCEDURE).

VALVE GUIDE REPLACEMENT PROCEDURE

1. Using a press, push the valve guide out toward the cylinder block side.
2. Rebore the valve guide hole in the cylinder head to match the oversize valve guide that is to be fitted.

⚠ CAUTION

Do not install a valve guide of the same size again.

Valve guide hole diameters in cylinder head

0.05 oversize: 12.05 – 12.07 mm (0.4744 – 0.4751 inch)

0.25 oversize: 12.25 – 12.27 mm (0.4823 – 0.4831 inch)

0.50 oversize: 12.50 – 12.52 mm (0.4921 – 0.4929 inch)

3. Press-fit the valve guide until it projects by the specified amount.

Standard value: 19.5 mm (0.768 inch)

⚠ CAUTION

- The valve guide must be installed from the upper side of the cylinder head.
- The valve guides differ in length on the intake and exhaust sides.

Valve guide length

Intake: 45.5 mm (1.791 inches)

Exhaust: 50.5 mm (1.988 inches)

4. After press-fitting the valve guide, insert a new valve and check that it slides smoothly.

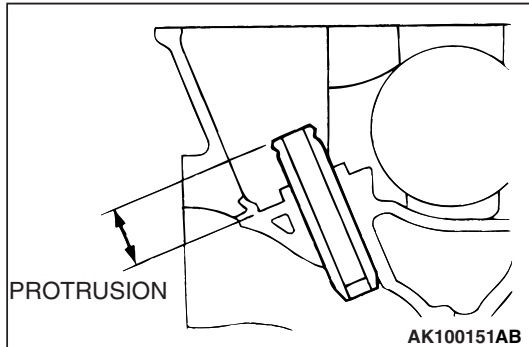

OIL PAN AND OIL PUMP

REMOVAL AND INSTALLATION

M1113008101014

APPLY ENGINE OIL TO ALL MOVING PARTS BEFORE INSTALLTION.

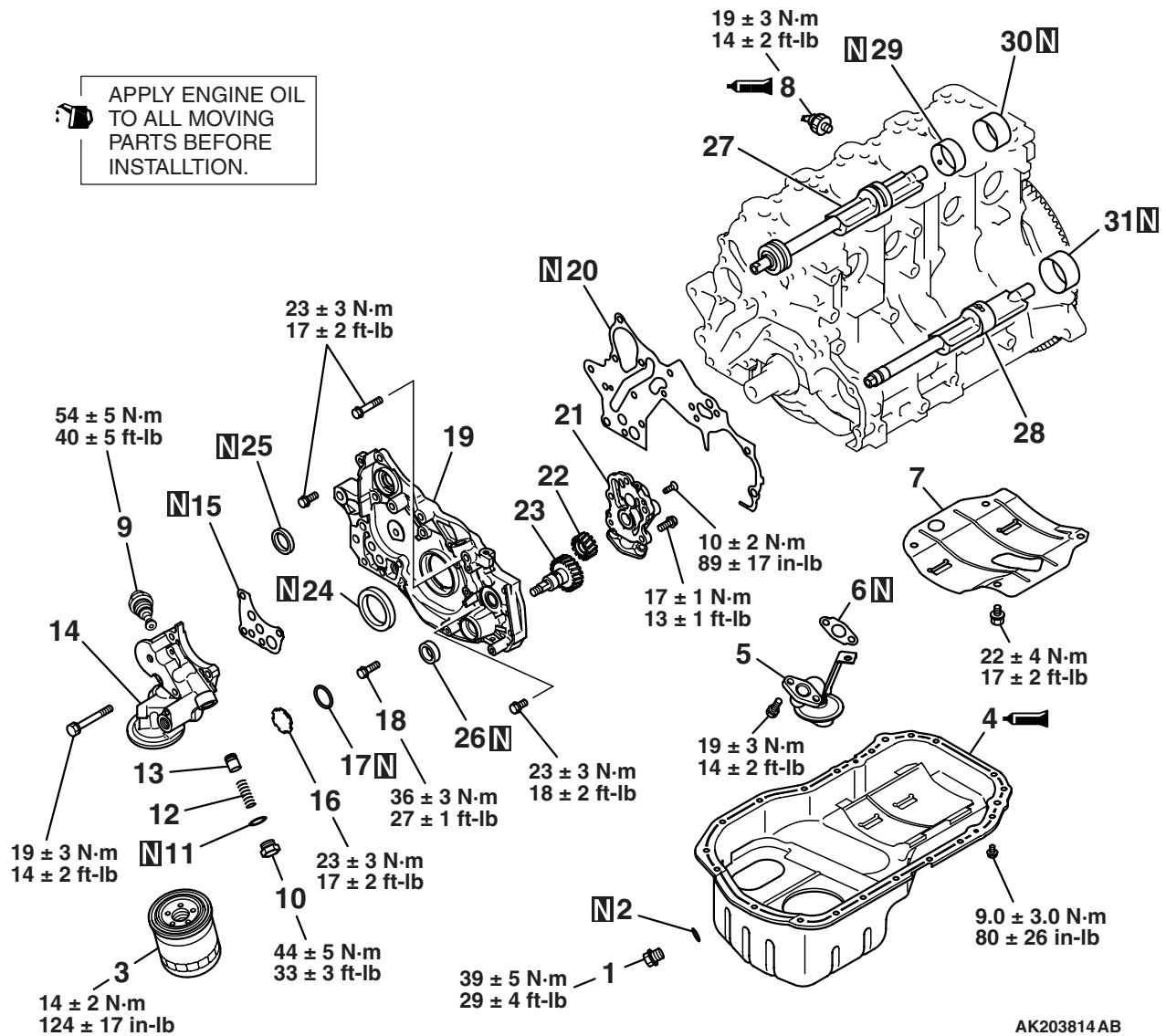

AK203814 AB

REMOVAL STEPS

1. DRAIN PLUG
- >>N<< 2. DRAIN PLUG GASKET
- >>M<< 3. OIL FILTER
- <<A>> >>L<< 4. OIL PAN
5. OIL SCREEN
6. OIL SCREEN GASKET
7. BAFFLE PLATER
- >>K<< 8. OIL PRESSURE SWITCH
9. OIL COOLER BY-PASS VALVE
10. RELIEF PLUG
11. GASKET
12. RELIEF SPRING
13. RELIEF PLUNGER
14. OIL FILTER BRACKET
15. OIL FILTER BRACKET GASKET
- <> >>J<< 16. PLUG CAP
17. O-RING

REMOVAL STEPS (Continued)

- <<C>> >>I<< 18. FLANGE BOLT
- >>H<< 19. OIL PUMP CASE
20. OIL PUMP CASE GASKET
21. OIL PUMP CASE COVER
- >>G<< 22. OIL PUMP DRIVEN GEAR
- >>G<< 23. OIL PUMP DRIVE GEAR
- >>F<< 24. CRANKSHAFT OIL SEAL
- >>E<< 25. COUNTERBALANCE SHAFT OIL SEAL
- >>D<< 26. OIL PUMP OIL SEAL
27. COUNTERBALANCE SHAFT, RIGHT
28. COUNTERBALANCE SHAFT, LEFT
- <<D>> >>C<< 29. COUNTERBALANCE SHAFT FRONT BEARING
- <<E>> >>B<< 30. COUNTERBALANCE SHAFT REAR BEARING, RIGHT
- <<E>> >>A<< 31. COUNTERBALANCE SHAFT REAR BEARING, LEFT

Required Special Tools:

- MB991603: Bearing Installer Stopper
- MD998012: Oil Pressure Switch Socket Wrench
- MD998054: Oil Pressure Switch Socket Wrench
- MD998162: Plug Wrench
- MD998285: Crankshaft Front Oil Seal Guide
- MD998371: Silent Shaft Bearing Puller
- MD998372: Silent Shaft Bearing Puller
- MD998375: Crankshaft Front Oil Seal Installer
- MD998705: Silent Shaft Bearing Installer
- MD998727: Oil Pan Remover
- MD998783: Plug Wrench Retainer

REMOVAL SERVICE POINTS**<<A>> OIL PAN REMOVAL**

1. Remove all oil pan bolts.
2. Drive in special tool MD998727 between the cylinder block and oil pan.

NOTE: Never use a screwdriver or chisel to remove the oil pan. It will deform the oil pan flange and result in oil leakage.

3. Gently hit the special tool on its corner (shoulder), then slide it along the oil pan to remove it.

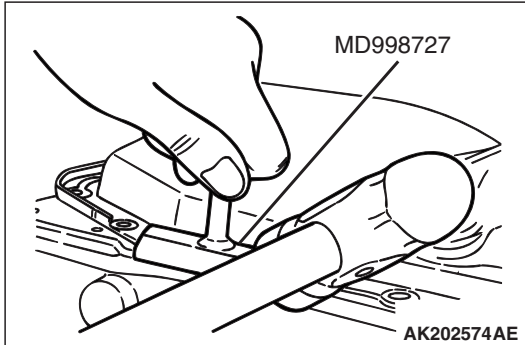
**<> PLUG CAP REMOVAL**

1. Fit special tool MD998162 on the plug cap, and then hold it in position with special tool MD998783.
2. Loosen the plug.
3. Remove special tools MD998783 and MD998162, and then the plug cap.

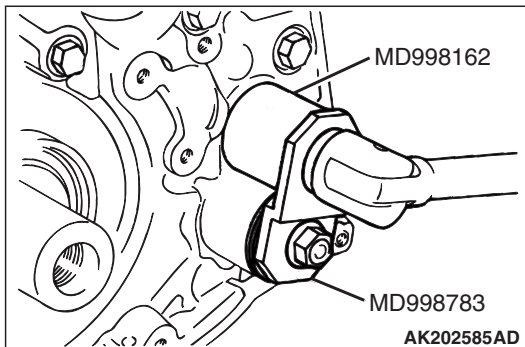
**<<C>> FLANGE BOLT REMOVAL**

1. Remove the plug on the side of the cylinder block.
2. Insert a Phillips screwdriver [shank diameter 8 mm (0.3 inch)] into the plug hole to lock the counterbalance shaft.

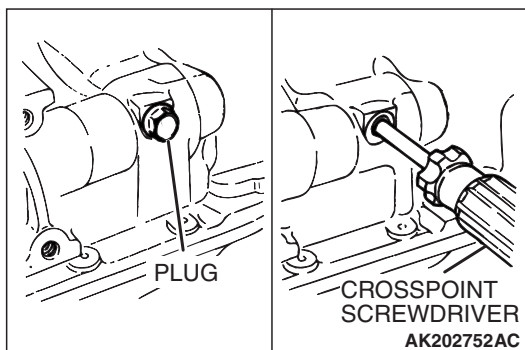

3. Loosen the flange bolt.

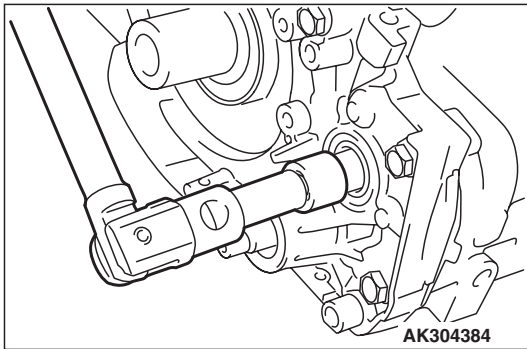

<<D>> COUNTERBALANCE SHAFT FRONT BEARING REMOVAL

Using special tool MD998371, remove the counterbalance shaft front bearing from the cylinder block.

NOTE: Be sure to remove the front bearing first. If it has not been removed, special tool MD998372 cannot be used for rear balance shaft bearing removal.

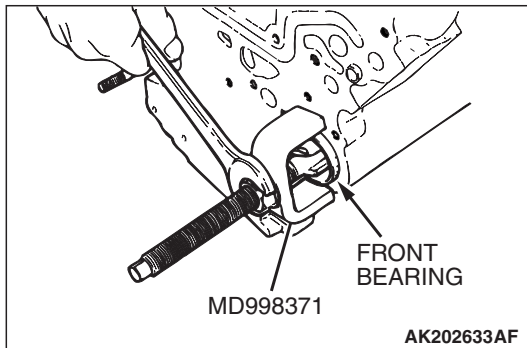

<<E>> COUNTERBALANCE SHAFT REAR BEARING REMOVAL

1. Install special tools MB991603 and MD998372 in front of the cylinder block when removing the left counterbalance shaft rear bearing.
2. Using special tool MD998372, remove the right counterbalance shaft rear bearing from the cylinder block.

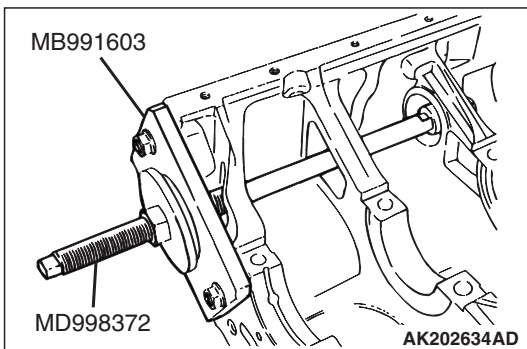

INSTALLATION SERVICE POINTS

>>A<< COUNTERBALANCE SHAFT REAR BEARING, LEFT INSTALLATION

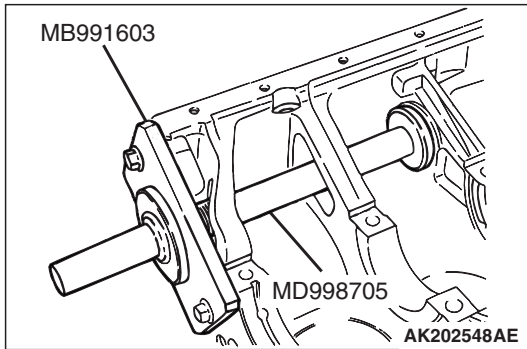

1. Install special tool MB991603 to the cylinder block.
2. Apply engine oil to the rear bearing outer surface and bearing hole in the cylinder block.
3. Using special tool MD998705, install the rear bearing.

NOTE: The left rear bearing has no oil holes.

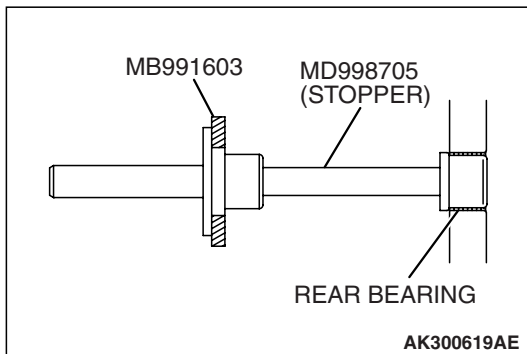

>>B<< COUNTERBALANCE SHAFT REAR BEARING, RIGHT INSTALLATION

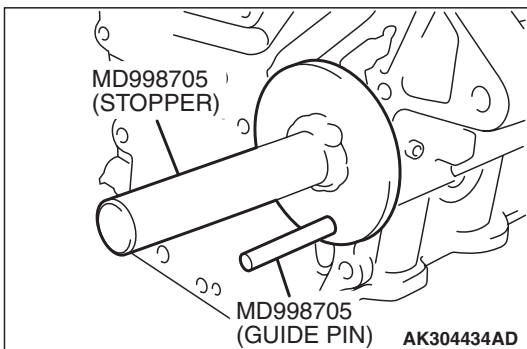

1. Apply engine oil to the bearing outer surface and bearing hole in the cylinder block.
2. Using special tool MD998705, install the rear bearing. Make sure that the oil hole of the bearing is aligned with that of the cylinder block.

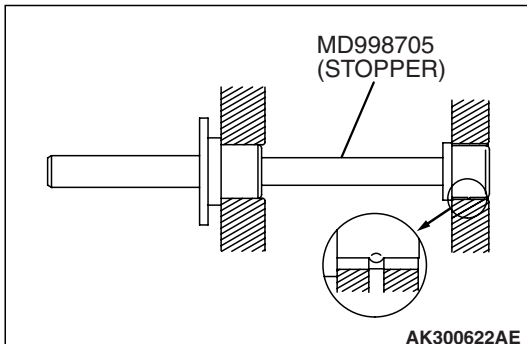

>>C<< COUNTERBALANCE SHAFT FRONT BEARING INSTALLATION

1. Apply engine oil to the front bearing outer surface and bearing hole in the cylinder.
2. Using special tool MD998705, install the front bearing. Make sure that the oil hole of the bearing is aligned with that of the cylinder block.

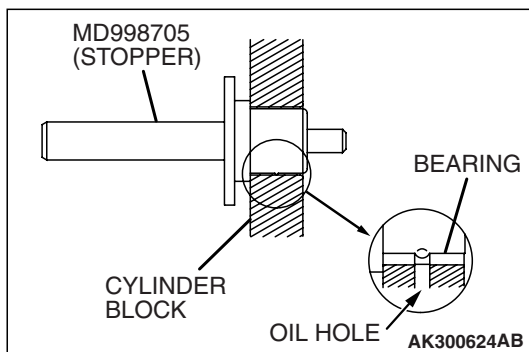
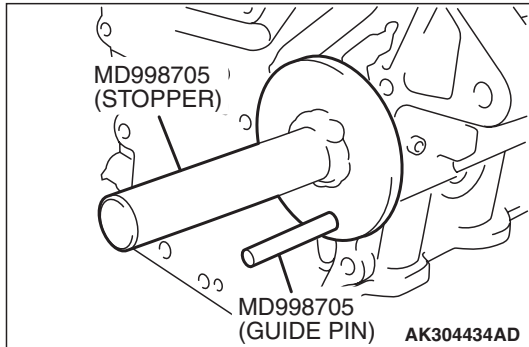

>>D<< COUNTERBALANCE SHAFT OIL SEAL INSTALLATION

Using a suitable socket wrench, install the counterbalance shaft oil seal into the front case.

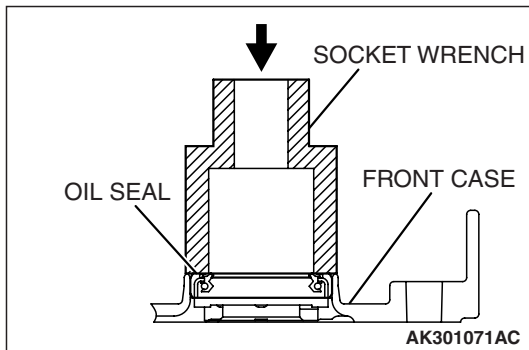

>>E<< OIL PUMP OIL SEAL INSTALLATION

Using a suitable socket wrench, install the oil pump oil seal into the front case.

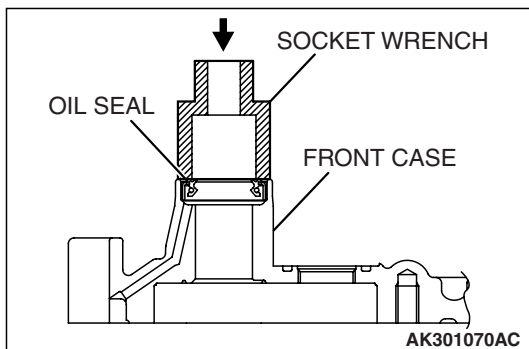

>>F<< CRANKSHAFT FRONT OIL SEAL INSTALLATION

Using special tool MD998375, install the crankshaft front oil seal into the front case.

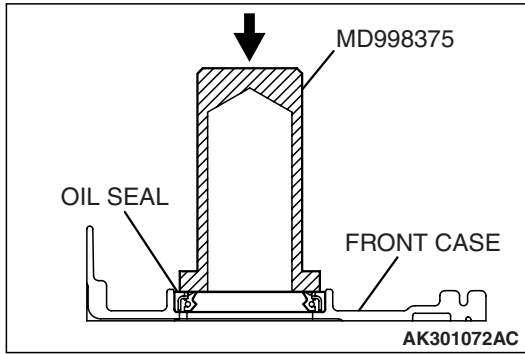
**>>G<< OIL PUMP DRIVEN GEAR/OIL PUMP DRIVE GEAR INSTALLATION**

Install the oil pump gears into the front case and line up the alignment marks.

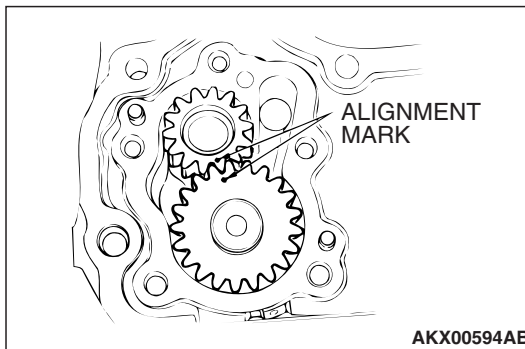
**>>H<< OIL PUMP CASE ASSEMBLY/OIL FILTER BRACKET INSTALLATION**

1. Set special tool MD998285 on the front end of crankshaft and apply a thin coat of engine oil to the outer surface of special tool MD998285.
2. Apply engine oil to the lip of the crankshaft front oil seal.

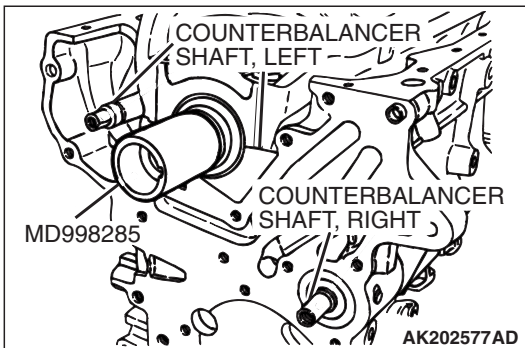

3. Install the oil pump case assembly together with the new front case gasket.
4. Install the oil filter bracket together with the new gasket.
5. Tighten the all flange bolts to the specified torque.

Tightening torque: 23 ± 3 N·m (17 ± 2 ft-lb)

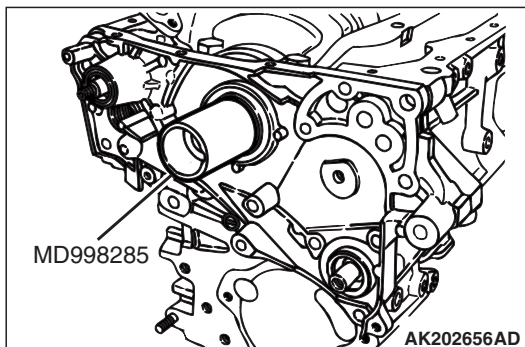

>>I<< FLANGE BOLT INSTALLATION

1. Insert a Phillips head screwdriver [shank diameter 8 mm (0.3 inch)] into the hole in the left side of the cylinder block to lock the counterbalance shaft.

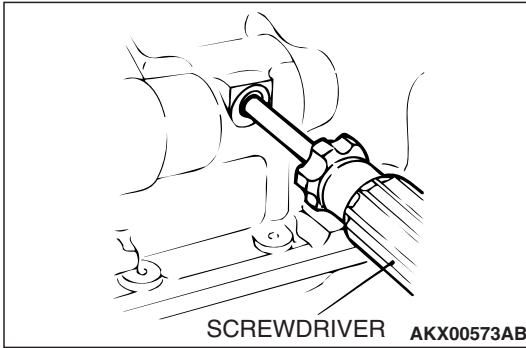

2. Secure the oil pump driven gear onto the left counterbalance shaft by tightening the flange bolt to the specified torque.

Tightening torque: 36 ± 3 N·m (27 ± 1 ft-lb)

3. Pull out the screwdriver and screw in the plug.

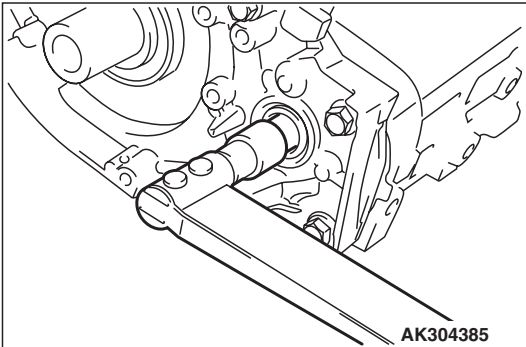

>>J<< PLUG CAP INSTALLATION

1. Install a new O-ring to the groove of the front case.
2. Install the plug cap to the front case.
3. Fit special tool MD998162 on the plug cap, and then hold it in position with special tool MD998783.
4. Tighten the plug cap to the specified torque.

Tightening torque: 23 ± 3 N·m (17 ± 2 ft-lb)

5. Remove special tools MD998783 and MD998162.

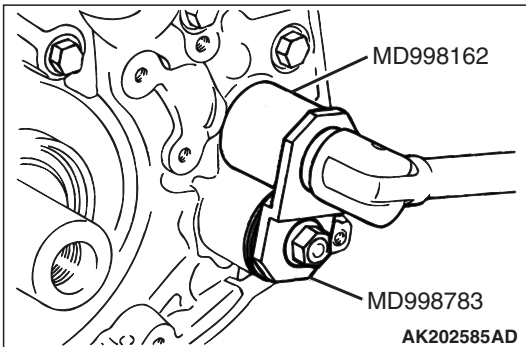

>>K<< OIL PRESSURE SWITCH INSTALLATION

⚠ CAUTION

Be careful not to block the oil passage with sealant.

1. Apply 3M™ AAD Part number 8672 or equivalent to the thread of engine oil pressure switch.

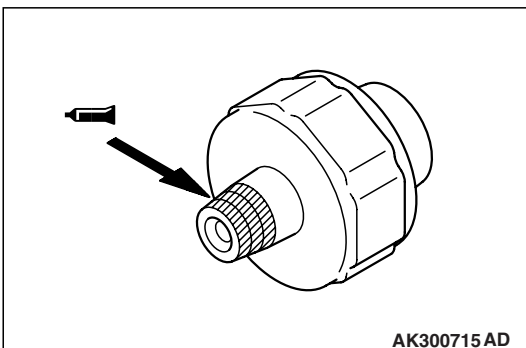

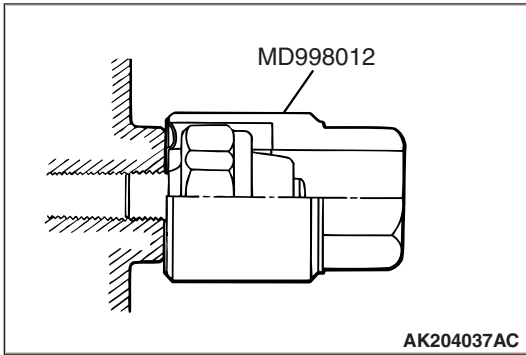

- Using special tool MD998012, tighten the engine oil pressure switch to the specified torque.

Tightening torque: 19 ± 3 N·m (14 ± 2 ft-lb)

>>L<< OIL PAN INSTALLATION

- Clean both gasket surfaces of oil pan and cylinder block.
- Apply a 4 mm (0.15 inch) diameter bead of sealant (MITSUBISHI Genuine Part number MD970389 or equivalent) to the flange of the oil pan.

Apply sealant as indicated by the broken line in the illustration; the grooves must be traced and the bolt holes must be surrounded with a bead of sealant.

- Install the oil pump case assembly to the front side of the cylinder block.

NOTE: Be sure to install the oil pan quickly while the sealant is wet (within 15 minutes).

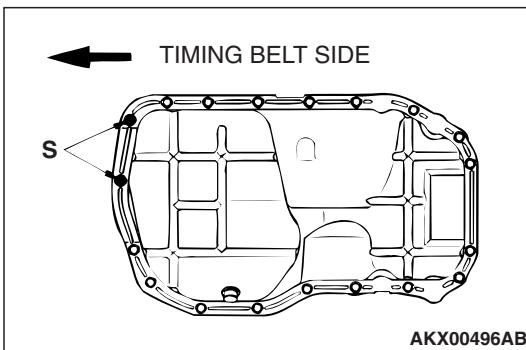
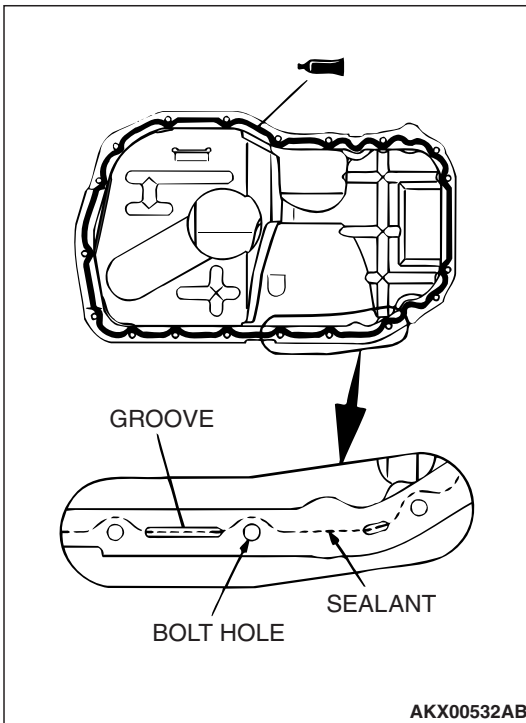

- Fit an 8 mm (0.30 inch) long bolt in each of the two holes identified by the letter "S" in the illustration and a 10 mm (0.39 inch) long bolt in each of the remaining 17 holes. Tighten all bolts to the specified torque.

Tightening torque: 9.0 ± 3.0 N·m (80 ± 26 in-lb)

NOTE: After installation, keep the sealed area away from the oil for approximately one hour.

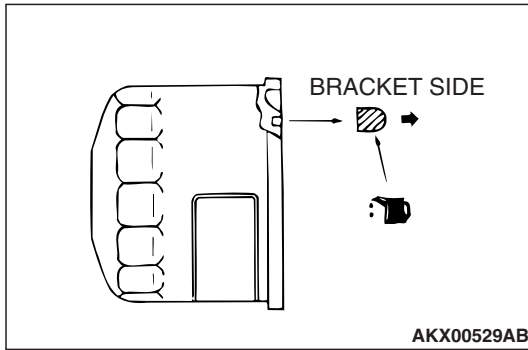

>>M<< OIL FILTER INSTALLATION

1. Clean the installation surface of the filter bracket.
2. Apply engine oil to the o-ring of the oil filter.
3. Install the oil filter to the bracket and tighten it to the specified torque.

Tightening torque: 14 ± 2 N·m (124 ± 17 in-lb)

4. If no torque wrench is available for tightening, use the following procedure:
 - (1) Screw in the oil filter until its o-ring contacts the oil filter bracket.
 - (2) Tighten the oil filter 3/4 turn.

>>N<< DRAIN PLUG GASKET INSTALLATION

CAUTION

If the gasket is installed in the wrong direction, oil leaks will occur.

Install the drain plug gasket in the direction shown.

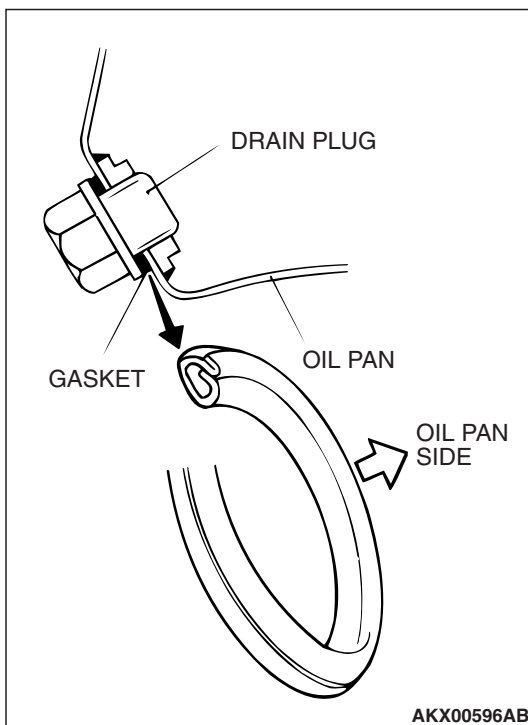

INSPECTION

M1113008200182

COUNTERBALANCER SHAFTS

1. Check that the oil holes are not blocked.
Clean if necessary.
2. Check the journals for seizure, damage and defective contact with bearings.
If any of these faults is found, replace the counterbalancer shaft, bearings and/or oil pump case assembly.

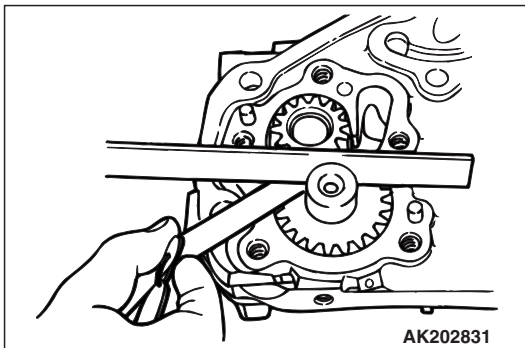
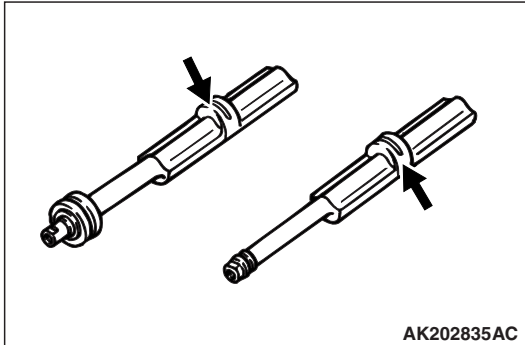

OIL PUMP

1. Install the drive and driven gears in the oil pump case.
2. Measure the gear side clearance using a straight edge and thickness gauge.

Standard values:

Drive gear 0.08 – 0.14 mm (0.0031 – 0.0055 inch)

Driven gear 0.06 – 0.12 mm (0.0023 – 0.0047 inch)

PISTON AND CONNECTING ROD

REMOVAL AND INSTALLATION

M1113008401349

 APPLY ENGINE OIL TO ALL MOVING PARTS BEFORE INSTALLTION.

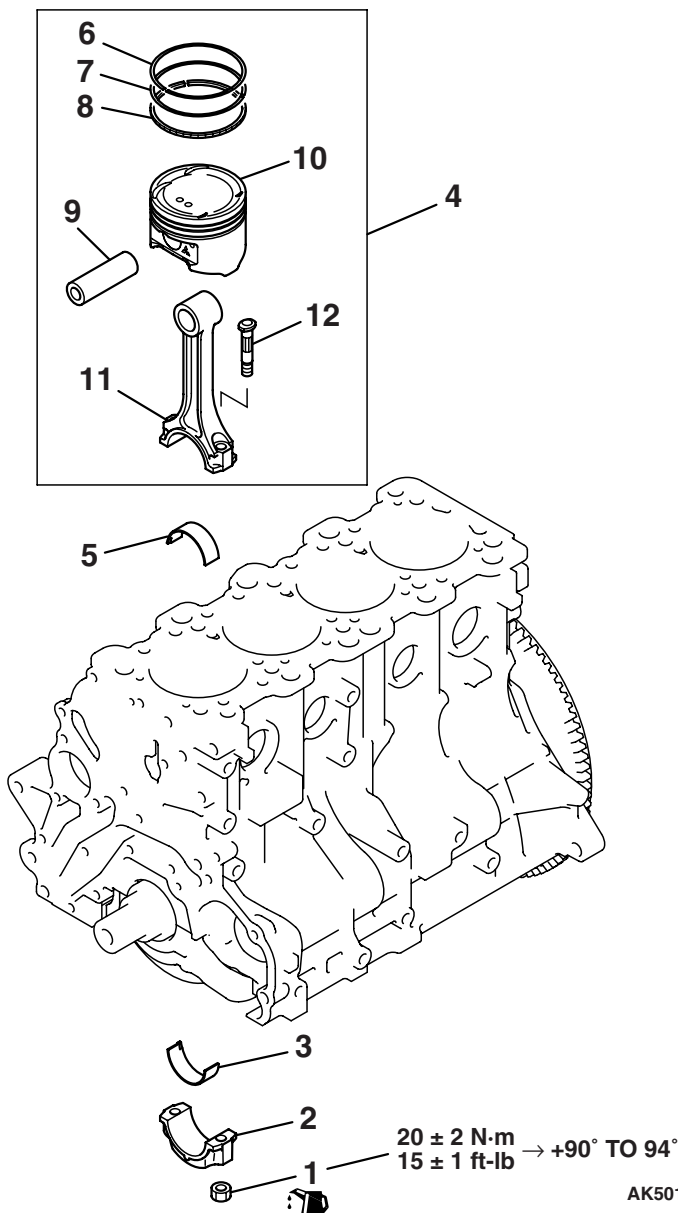

- REMOVAL STEPS**
- >>G<<1. NUT
 - <<A>> >>F<<2. CONNECTING ROD CAP
 - >>E<<3. CONNECTING ROD BEARING
 - <> >>D<<4. PISTON AND CONNECTING ROD
 - >>E<<5. CONNECTING ROD BEARING
 - >>C<<6. PISTON RING NO.1

- REMOVAL STEPS (Continued)**
- >>C<<7. PISTON RING NO.2
 - >>B<<8. OIL RING
 - <<C>> >>A<<9. PISTON PIN
 - 10. PISTON
 - 11. CONNECTING ROD
 - 12. BOLT

Required special tool:

- MIT216941: Piston Pin Setting Tool
- MB992010: Bolt Guide

REMOVAL SERVICE POINTS

<<A>> CONNECTING ROD CAP REMOVAL

1. Mark the cylinder number on the side of the connecting rod big end for correct reassembly.
2. Keep the removed connecting rods, caps, and bearings in that order according to the cylinder number.

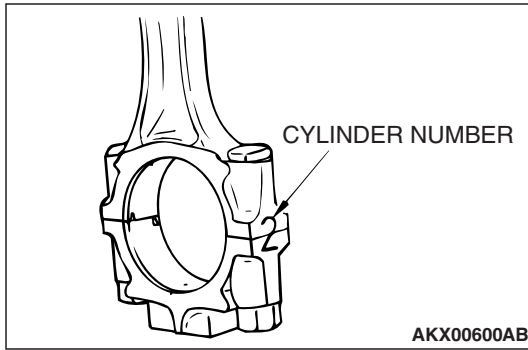

<> PISTON AND CONNECTING ROD ASSEMBLY REMOVAL

1. Not to damage the crank pin, attach a special tool MB992010, to the connecting rod bolt.
2. Remove the piston and connecting rod assembly from the cylinder block.

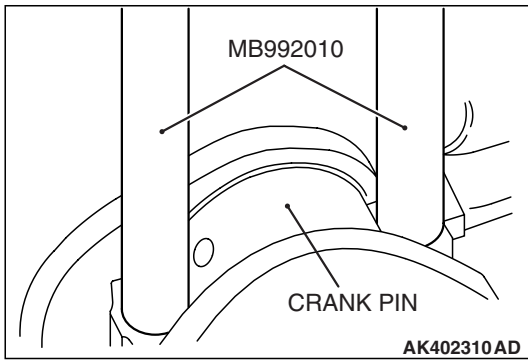

<<C>> PISTON PIN REMOVAL

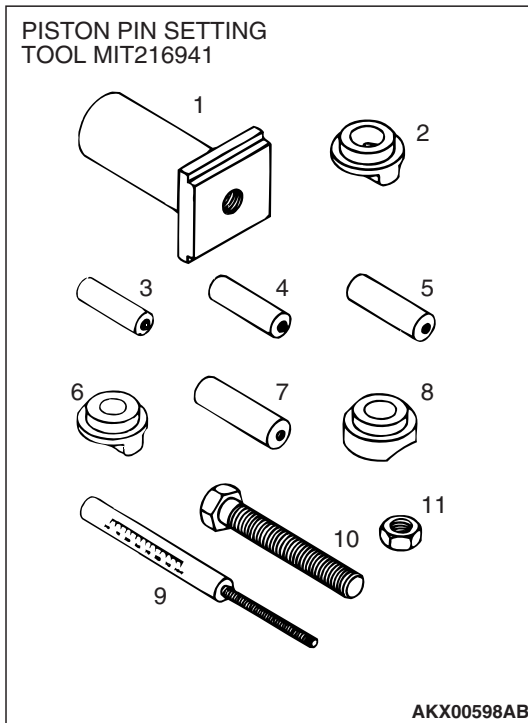

ITEM NO.	PART NO.	DESCRIPTION
1.	MIT310134	Base
2.	MIT310136	Piston support
3.	MIT310137	Connecting rod guide pin
4.	MIT310138	Connecting rod guide pin
5.	MIT310139	Connecting rod guide pin
6.	MIT310140	Piston support
7.	MIT310141	Connecting rod guide pin
8.	MIT310142	Piston support
9.	MIT48143	Press pin
10.	216943	Stop screw
11.	10396	Nut

1. Remove the stop screw from the base.
2. Select the correct piston support for your application (See above). Fit the piston support onto the base. Place the base on press support blocks.

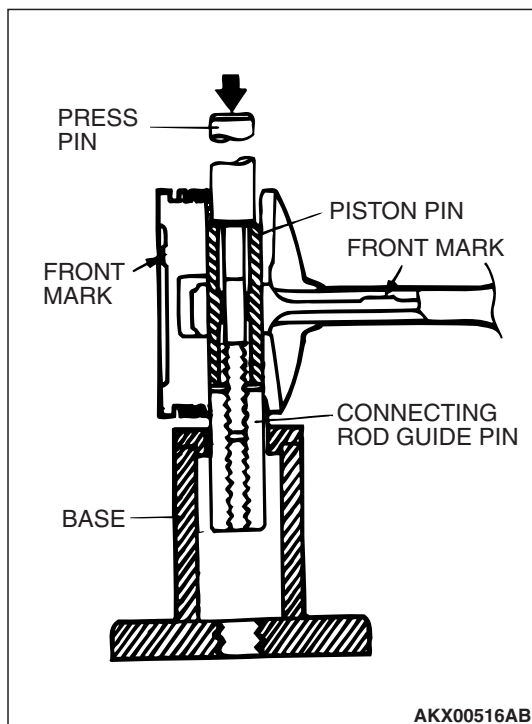

3. Insert the press pin through the piston pin hole. Select the correct connecting rod guide pin (See above). Thread the guide pin onto the threaded portion of the press pin.

CAUTION

To avoid piston damage, the piston support must seat squarely against the piston. Verify that the piston pin will slide through the hole in the piston support.

4. Position the piston assembly on the piston support in the press. With the press pin up as shown, insert the guide pin through the hole in the piston and through the hole in the piston support.
5. Press the piston pin out of the assembly.
6. Remove the piston pin from the press pin.

INSTALLATION SERVICE POINTS

>>A<< PISTON PIN INSTALLATION

1. When replacing the piston, read off the cylinder bore size mark on the cylinder block as illustrated, and select a piston according to the flowing table.

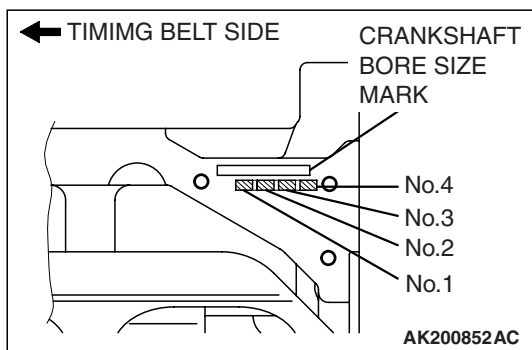

CYLINDER BORE SIZE MARK	PISTON SIZE MARK
I	A
II	None
III	C

NOTE: The piston size mark shows on the top of the piston.

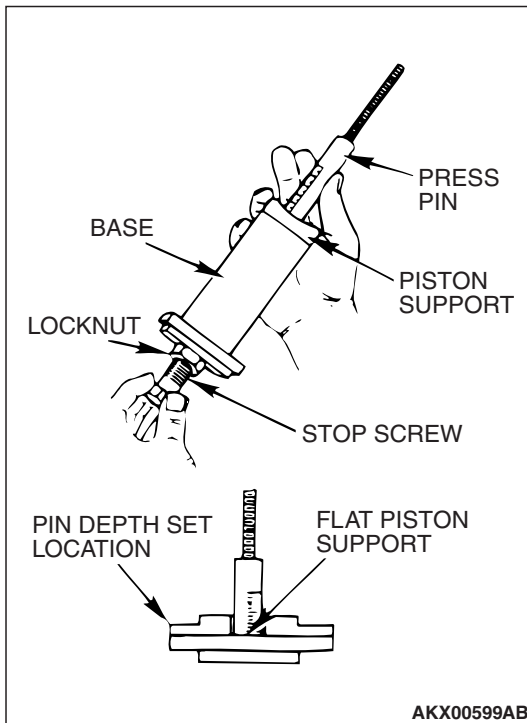

2. Thread the stop screw and lock nut assembly into the base. Fit the correct piston support on top of the base. Insert the press pin, threaded end up, into the hole in the piston support until the press pin touches the stop screw.
3. Using the markings on the press pin, adjust the stop screw to the depth shown on the instruction for special tool MIT216941.

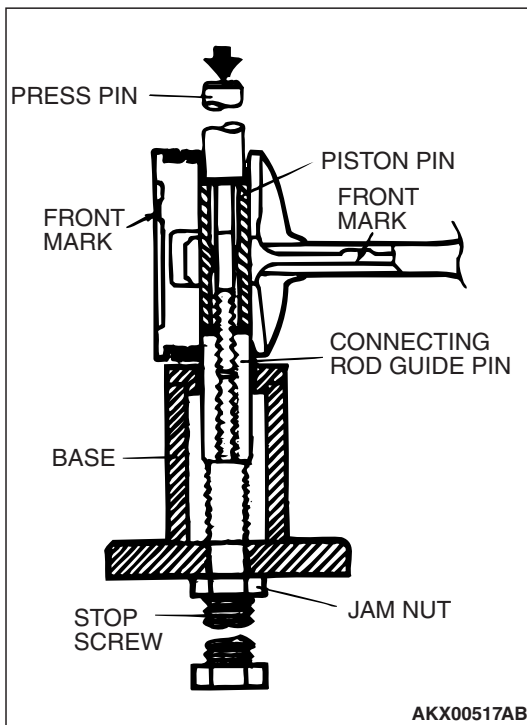

4. Place the base on press support blocks.
5. Slide the piston pin over the threaded end of the press pin, and thread the correct guide pin up against it.
6. Coat the piston pin with engine oil. With the connecting rod held in position, slide the guide pin through the piston and connecting rod.
7. Press the piston pin through the connecting rod until the guide pin contacts the stop screw.

CAUTION

Due to production tolerance variations, it is necessary to visually inspect the piston pin depth after installation to verify that the piston pin is centered. Adjust if necessary.

8. Remove the piston assembly from the base. Remove the guide pin and press pin from the assembly.

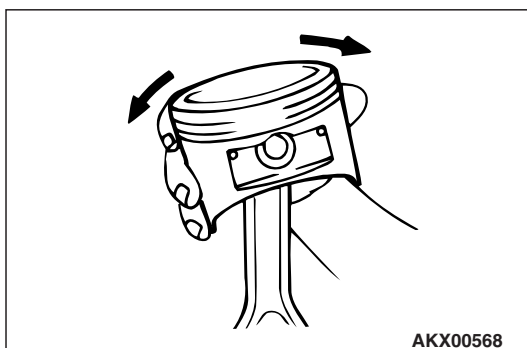

9. Check that the piston moves smoothly.

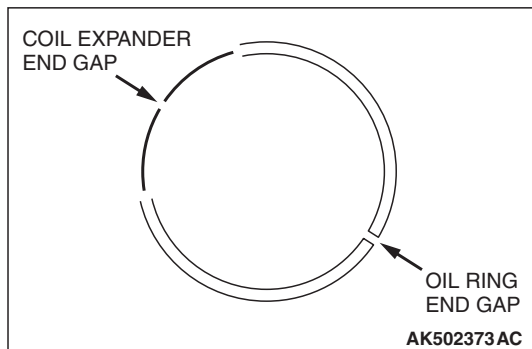

>>B<< OIL RING INSTALLATION

1. Fit the oil ring coil expander and oil ring into the piston ring groove.

NOTE: The oil ring and coil expander may be installed in either direction.

NOTE: New coil expander and oil ring are colored for identification of their sizes.

SIZE	IDENTIFICATION COLOR
Standard	None
0.50 mm (0.020 in) oversize diameter	Red
1.00 mm (0.040 in) oversize diameter	Yellow

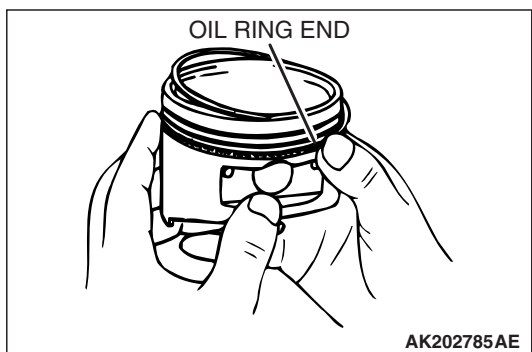

⚠ CAUTION

Do not use a piston ring expander when installing side rail.

2. To install each coil expander, first fit one end of the oil ring into the piston groove, then press the remaining portion progressively into position by finger as shown in the drawing.
3. Make sure that the oil ring move smoothly in both directions.

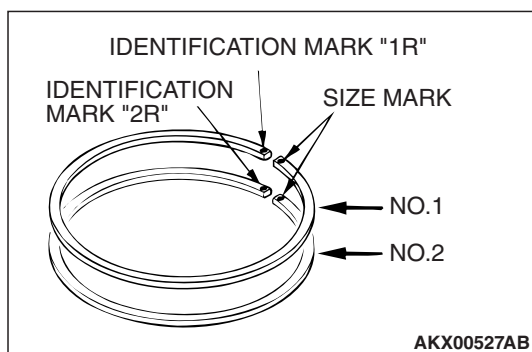

>>C<< PISTON RING NUMBER 2 / PISTON RING NUMBER 1 INSTALLATION

1. To prevent wrong installation, check the identification mark of each piston ring. The identification mark is stamped near the ring gap:

Identification mark:

Number 1 ring: 1R

Number 2 ring: 2R

NOTE: Size marks on piston rings are as follows.

SIZE	SIZE MARK
Standard	No.1 ring (None) White paint to the ring periphery
	No.2 ring (None) Black paint to the ring periphery
0.50 mm (0.020 in) oversize diameter	50
1.00 mm (0.040 in) oversize diameter	100

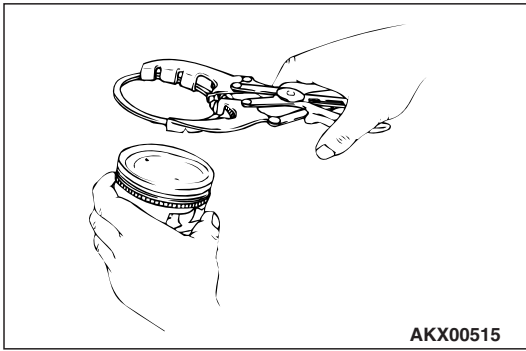

2. Using the piston ring expander, fit number 2 into the number 2 groove of piston.
NOTE: Install piston rings with identification mark facing up, to the piston crown side.
3. Install the number 1 piston ring in the same manner as step 2.

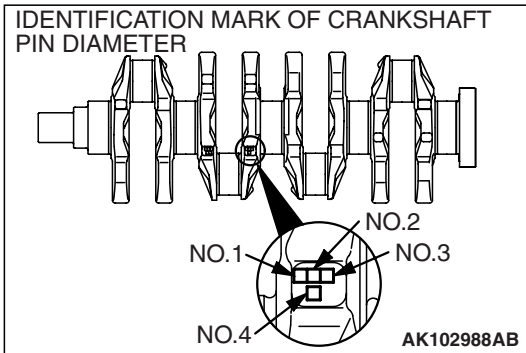

>>D<< CONNECTING ROD BEARING INSTALLATION

1. Measure the crankshaft pin diameter and confirm its classification from the following table. In the case of a crankshaft supplied as a service part, identification marks of its pins are stamped at the positions shown in the illustration.

CRANKSHAFT PIN OUTSIDE DIAMETER		CONNECTING ROD BEARING
IDENTIFICATION MARK	SIZE mm (in)	IDENTIFICATION MARK
I	44.995 – 45.000 (1.7715 – 1.7717)	0
II	44.985 – 44.995 (1.7711 – 1.7715)	1
III	44.980 – 44.985 (1.7709 – 1.7711)	2

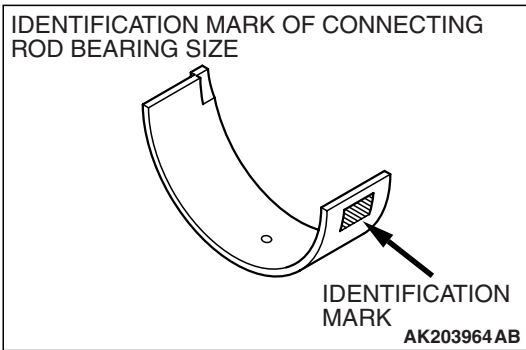

2. If the crankshaft pin outside diameter identification mark is "I," for example, select a bearing whose identification mark is "0."

If there is no identification mark or no identification color paint on the crankshaft, measure the pin outside diameter and select a bearing appropriate for the measured value.

3. Install the selected bearing in the big end and in the cap of the connecting rod.

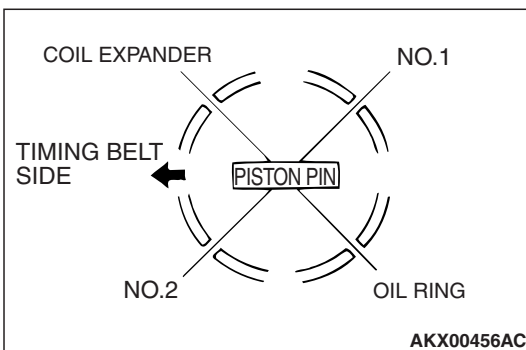

>>E<< PISTON AND CONNECTING ROD INSTALLATION

1. Apply engine oil on the circumference of the piston, piston rings, and oil ring.
2. Arrange the piston ring and oil ring gaps (oil ring and coil expander) as shown in the illustration.
3. Rotate the crankshaft so that crank pin is on the center of the cylinder bore.

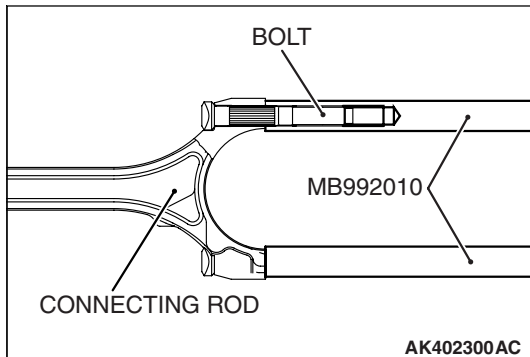

4. Not to damage the crank pin, attach a special tool MB992010, to the connecting rod bolt.

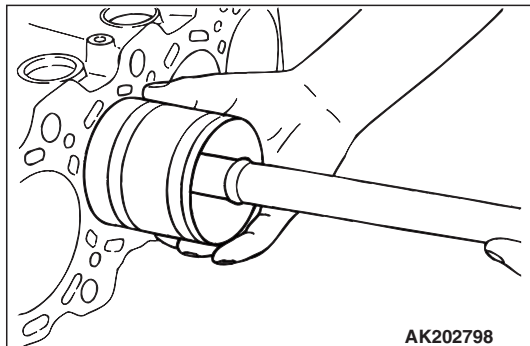

5. Use suitable thread protectors on the connecting rod bolts before inserting the piston and connecting rod assembly into the cylinder block.
Care must be taken not to nick the crank pin.
6. Insert the piston and connecting rod assembly into the cylinder with front mark on the piston crown pointing to the timing belt side.

⚠ CAUTION

Make sure that the piston and connecting rod do not touch the oil jet during installation.

7. Using a suitable piston ring compressor tool, Install the piston and connecting rod assembly into the cylinder block.

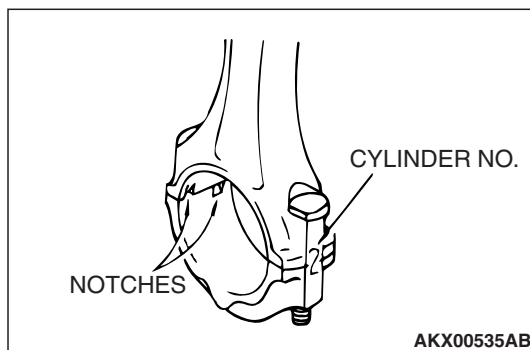

>>F<< CONNECTING ROD CAP INSTALLATION

1. Verifying the mark made during disassembly, install the bearing cap to the connecting rod. If the connecting rod is new with no index mark, make sure that the bearing locking notches are on the same side as shown.

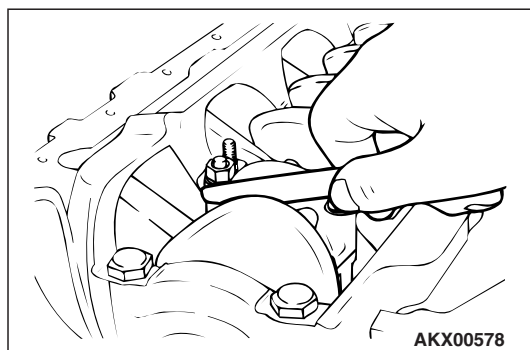

2. Make sure that the connecting rod big end side clearance meets the specification.

Standard value: 0.10 – 0.25 mm (0.004 – 0.009 inch)

Limit: 0.4 mm (0.015 inch)

>>G<< CONNECTING ROD CAP NUT TIGHTENING

1. The connecting rod bolts should be examined before reuse. If the bolt threads are damaged, the bolt should be replaced. Hand-thread the nut to the full length of the bolt threads. If the nut does not run down smoothly, the bolt should be replaced.
2. Before installation of each nut, apply engine oil to the threaded portion and bearing surface of the nut.
3. Loosely tighten each nut to the bolt.
4. Then tighten the nuts alternately to a torque of 20 ± 2 N·m (15 ± 1 ft-lb) to install the cap properly.
5. Make a paint mark on the head of each nut.

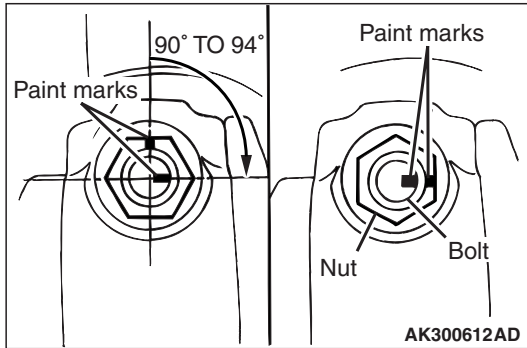
**CAUTION**

- If the nut is turned less than 90 degree angle, proper fastening may not be achieved. Be careful to tighten the nut exactly at a 90 degree angle.
 - If the nut is overtightened (exceeding 94 degree angle), loosen the nut completely and then retighten it by repeating the tightening procedure from step 3.
6. Make a paint mark on the bolt end at the position 90 degree angle to 94 degree angle from the paint mark made on the nut in the direction of tightening the nut.
 7. Turn the nut further 90 degree angle to 94 degree angle and make sure that the paint marks on the nut and bolt are aligned.

INSPECTION

PISTON RING

1. Check for side clearance.

If the limit is exceeded, replace the ring or piston, or both.

Standard value:

No.1: 0.03 – 0.07 mm (0.0012 – 0.0028 inch)

No.2: 0.02 – 0.06 mm (0.0008 – 0.0024 inch)

Limit:

No.1: 0.1 mm (0.0039 inch)

No.2: 0.1 mm (0.0039 inch)

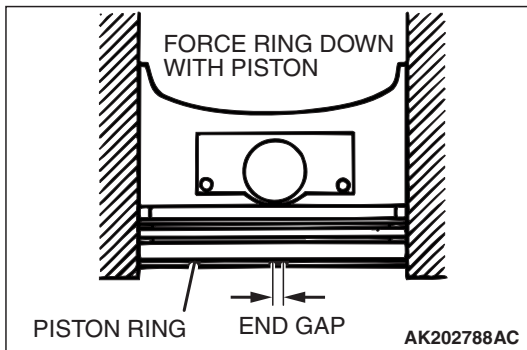
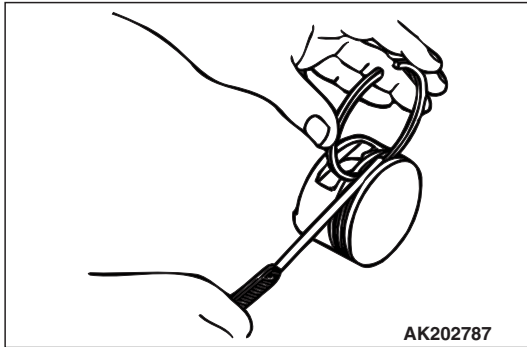

2. Install the piston ring into the cylinder bore. Force the ring down with a piston, the piston crown being in contact with the ring, to correctly position it at right angles to the cylinder wall. Then, measure the end gap with a feeler gauge.

If the end gap is excessive, replace the piston ring.

Standard value:

No.1 ring: 0.20 – 0.30 mm (0.0079 – 0.0118 inch)

No.2 ring: 0.35 – 0.50 mm (0.0128 – 0.0197 inch)

Oil ring: 0.10 – 0.40 mm (0.0039 – 0.0157 inch)

Limit:

No.1, No.2 ring: 0.8 mm (0.031 inch)

Oil ring: 1.0 mm (0.039 inch)

CRANKSHAFT PIN OIL CLEARANCE (PLASTIGAGE METHOD)

1. Remove oil from the crankshaft pin and connecting rod bearing.
2. Cut the plastigage to the same length as the width of bearing and place it on crankshaft pin in parallel with its axis.
3. Install the connecting rod cap carefully and tighten the nuts to the specified torque. (See "Connecting rod cap nut tightening" procedure.)
4. Carefully remove the connecting rod cap.
5. Measure the width of the plastigage at its widest part by using a scale printed on its package.

Standard value: 0.03 – 0.05 mm (0.0012 – 0.0020 inch)

Limit: 0.1 mm (0.004 inch)

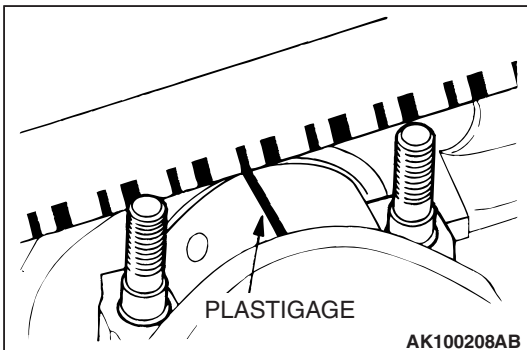

CRANKSHAFT AND CYLINDER BLOCK

REMOVAL AND INSTALLATION

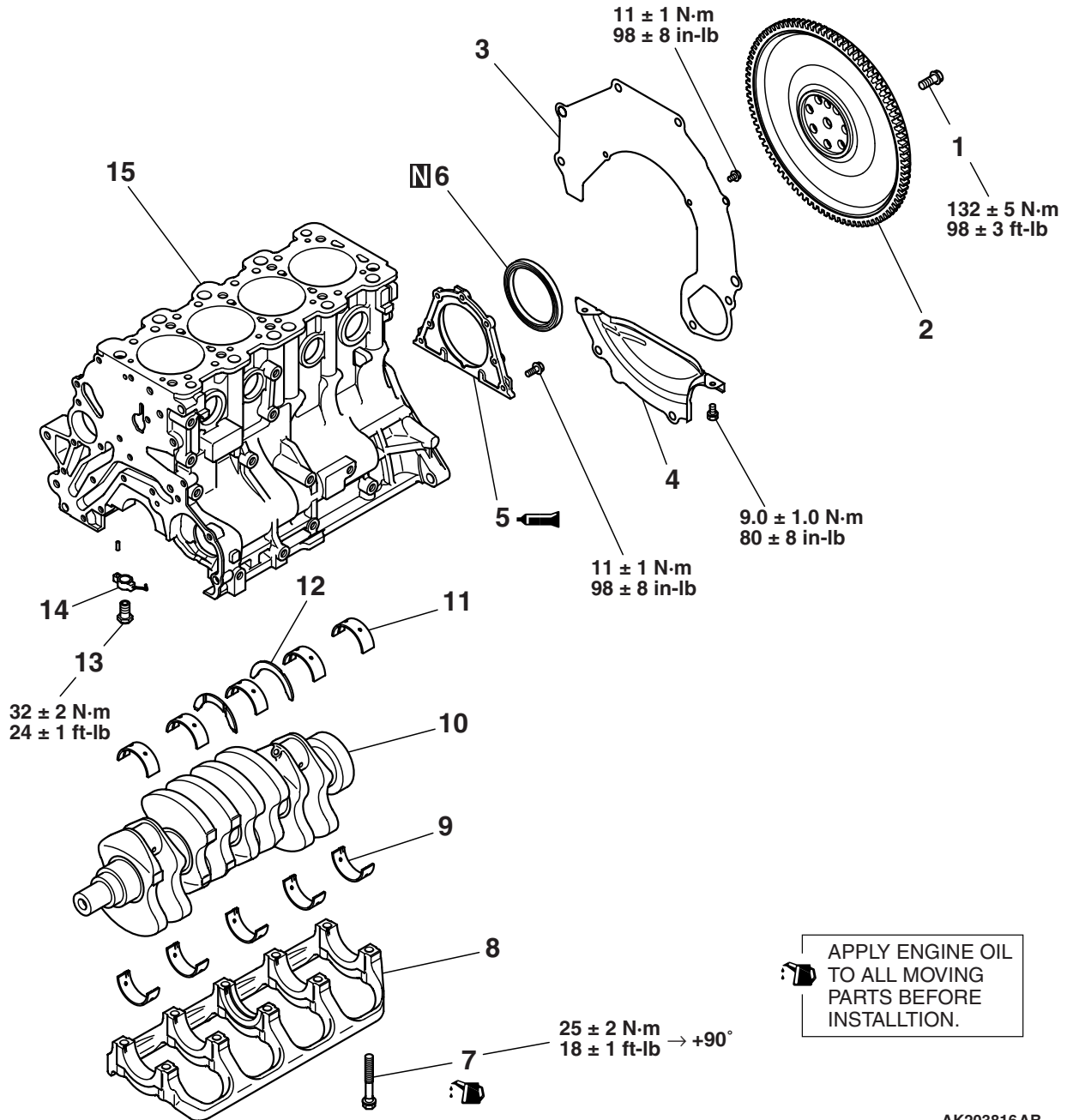

APPLY ENGINE OIL TO ALL MOVING PARTS BEFORE INSTALLATION.

AK203816 AB

REMOVAL STEPS

1. FLYWHEEL BOLT
2. FLYWHEEL
3. REAR PLATE
4. BELL HOUSING COVER
- >>E<< 5. OIL SEAL CASE
- >>D<< 6. OIL SEAL
- >>C<< 7. BEARING CAP BOLT
- >>C<< 8. BEAM BEARING CAP

REMOVAL STEPS (Continued)

- >>B<< 9. CRANKSHAFT BEARING, LOWER
10. CRANKSHAFT
- >>B<< 11. CRANKSHAFT BEARING, UPPER
- >>A<< 12. THRUST BEARING
13. CHECK VALVE
14. OIL JET
15. CYLINDER BLOCK

Required Special Tools:

- MD998776: Crankshaft Rear Oil Seal Installer
- MB990938: Handle

INSTALLATION SERVICE POINTS

>>A<< CRANKSHAFT THRUST BEARING INSTALLATION

1. Install the two thrust bearings in the number 3 bearing bore in the cylinder block. For easier installation, apply engine oil to the bearings; this will help hold them in position.
2. The thrust bearings must be installed with their groove side toward the crankshaft web.

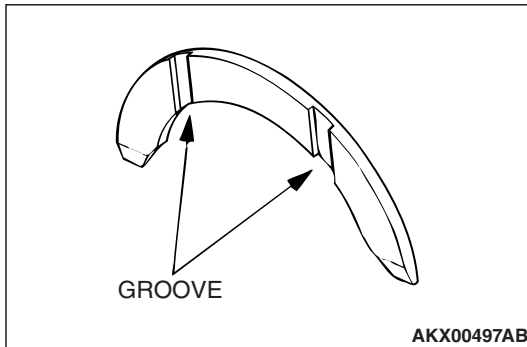

>>B<< CRANKSHAFT BEARING INSTALLATION

When bearing replacement is required, select and install the correct bearing by the following procedure.

1. Measure the crankshaft journal diameter and confirm its classification from the following table. In the case of a crankshaft supplied as a service part, identification marks of its journals are stamped at the positions shown in the illustration.

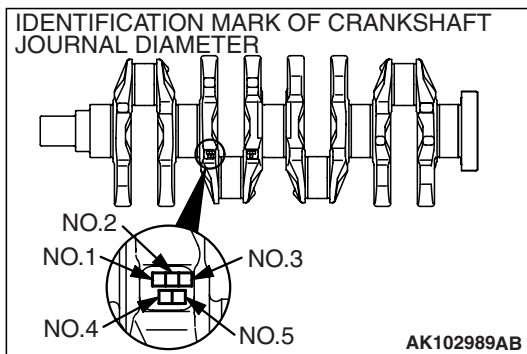

2. The cylinder block bearing bore diameter identification marks are stamped at the position shown in the illustration from left to right, beginning at No.1.

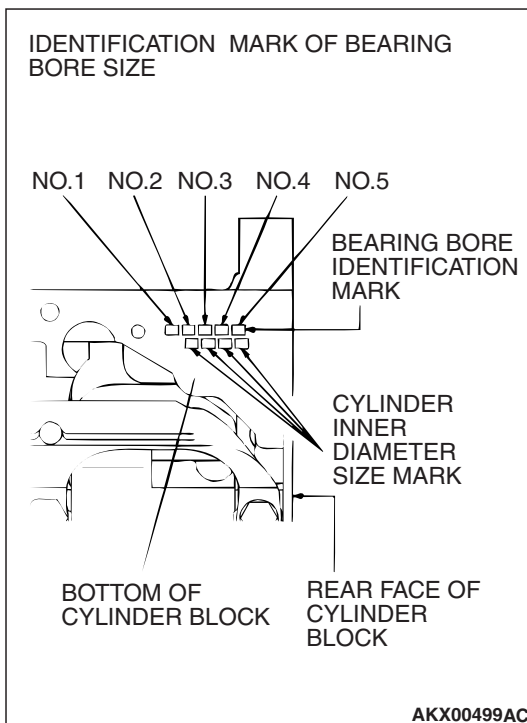

CRANKSHAFT JOURNAL OUTSIDE DIAMETER		CYLINDER BLOCK BEARING BORE	CRANKSHAFT BEARING
IDENTIFICATION MARK	SIZE mm (in)	IDENTIFICATION MARK	IDENTIFICATION MARK
0	56.994 – 57.000 (2.2439 – 2.2441)	0	0
		1	1
		2	2
1	56.988 – 56.994 (2.2436 – 2.2439)	0	1
		1	2
		2	3
2	56.982 – 56.988 (2.2434 – 2.2436)	0	2
		1	3
		2	4

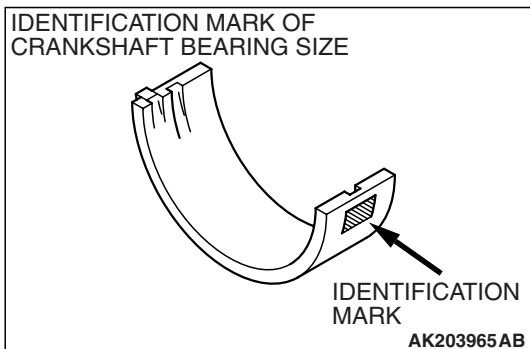

For example, if the crankshaft journal outside diameter identification mark is "0" and cylinder block bearing bore identification mark is "1," select a bearing whose identification mark is "1." If there is no identification mark stamp on the crankshaft, measure the journal outside diameter and select a bearing appropriate for the measured value.

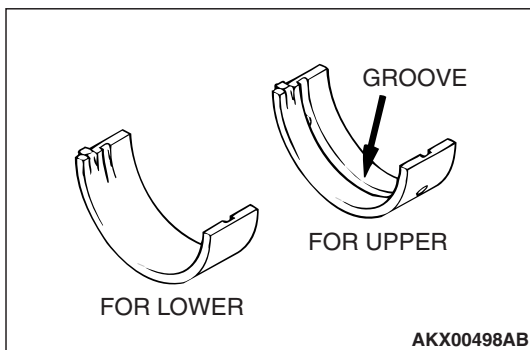

3. Install the bearings having an oil groove to the cylinder block.
4. Install the bearings having no oil groove to the bearing cap.

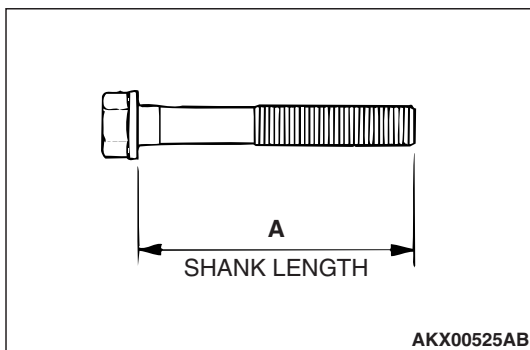

>>C<< BEARING CAP/BEARING CAP BOLT INSTALLATION

1. Install the bearing caps so that the arrow points to the timing belt side.
2. Before installing the bearing cap bolts, check that the shank length of each bolt meets the limit. If it exceeds the limit, replace the bolt.

Limit (A): 71.1 mm (2.79 inches)
3. Apply engine oil to the threaded portion and bearing surface of the bolt.

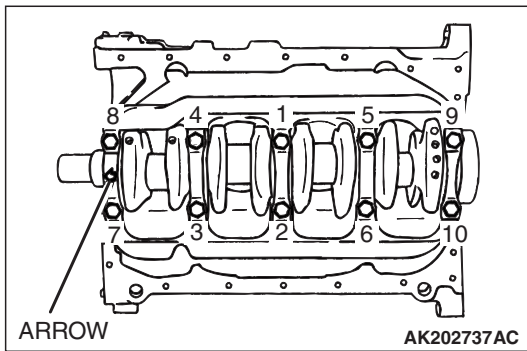

4. Tighten the bolts to 25 ± 2 N·m (18 ± 1 ft-lb) in the tightening sequence shown.

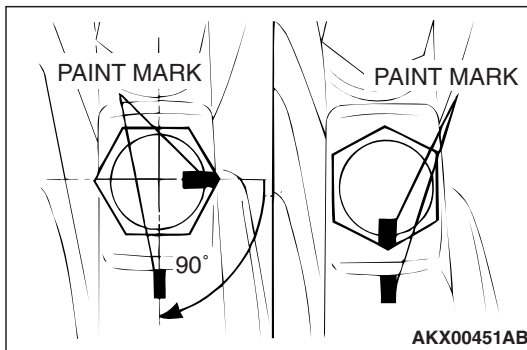

5. Make a paint mark on the head of each bolt.
6. Make a paint mark on the bearing cap at the position 90 degree angle from the paint mark made on the bolt in the direction of tightening the bolt.

CAUTION

- If the bolt is overtightened, loosen the bolt completely and then retighten it by repeating the tightening procedure from step 4.
 - If the bolt is turned less than 90 degree angle, proper fastening performance may not be achieved. Be sure to turn the bolt exactly 90 degree angle.
7. Turn each bolt 90 degree angle in the tightening sequence specified in step 4, and make sure that the paint marks on the bolt and cap are aligned.
8. Make sure that the crankshaft turns smoothly and the end play is correct. If the end play exceeds the limit, replace the number 3 crankshaft bearings.

Standard value: 0.05 – 0.25 mm (0.002 – 0.009 inch)
Limit: 0.40 mm (0.0015 inch)

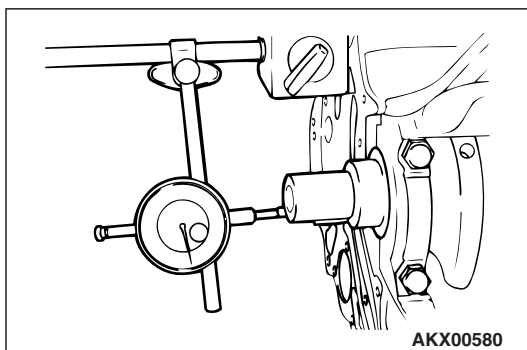

>>D<< OIL SEAL INSTALLATION

Using special tools MD998776 and MB990938, press-fit the oil seal in the case.

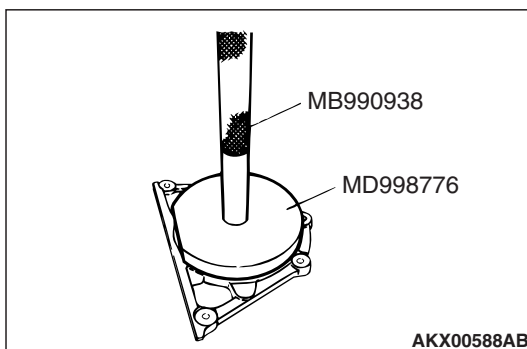

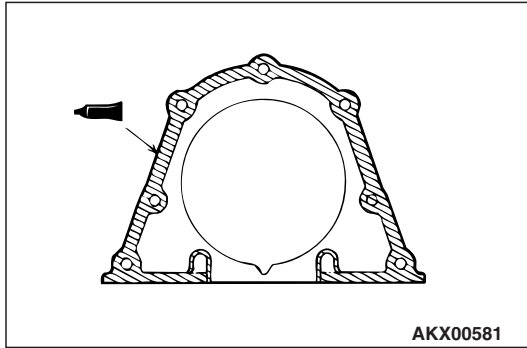
**>>E<< SEALANT APPLICATION TO OIL SEAL CASE**

1. Apply sealant (MITSUBISHI Genuine Part number MD970389 or equivalent) to the gasket surface of oil seal case.

NOTE: Be sure to install the case quickly while the sealant is wet (within 15 minutes).

2. Apply engine oil to the oil seal lip, and then install the oil seal case onto the cylinder block.

NOTE: After installation, keep the sealed area away from the oil for approximately one hour.

INSPECTION

M1113008800344

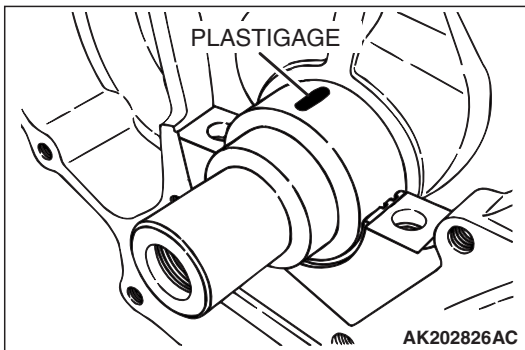
**CRANKSHAFT JOURNAL OIL CLEARANCE
<PLASTIGAGE METHOD>**

1. Remove oil from the crankshaft journal and crankshaft bearing.
2. Install the crankshaft.
3. Cut the plastigage to the same length as the width of bearing and place it on journal in parallel with its axis.

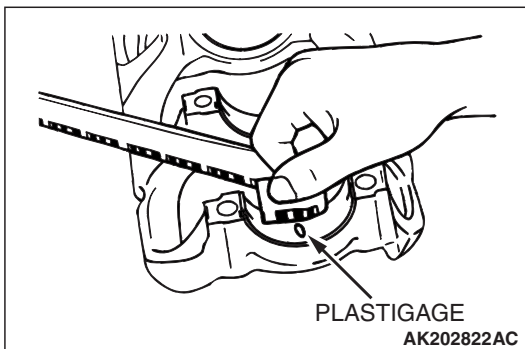

4. Install the crankshaft bearing cap carefully and tighten the bolts to the specified torque.
5. Carefully remove the crankshaft bearing cap.
6. Measure the width of the plastigage at its widest part by using a scale printed on the plastigage package.

Standard value: 0.03 – 0.04 mm (0.0012 – 0.0015 inch)
Limit: 0.1 mm (0.003 inch)

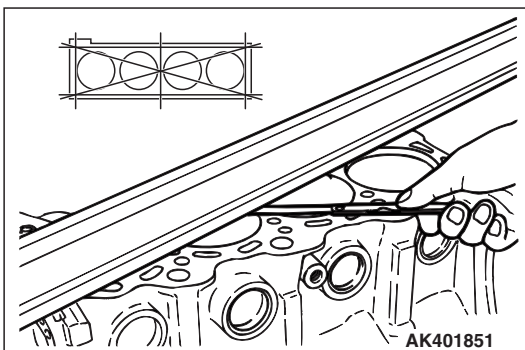
CYLINDER BLOCK

1. Visually check for scratches, rust, and corrosion.
Use also a flaw detecting agent for the check. If defects are evident, correct or replace.
2. Using a straightedge and feeler gauge, check the block top surface for warpage. Make sure that the surface is free from gasket chips and other foreign matter.

Standard value: 0.05 mm (0.0020 inch)
Limit: 0.1 mm (0.003 inch)

3. If the distortion is excessive, correct within the allowable limit or replace.

Grinding limit: 0.2 mm (0.007 inch)

***Includes/combined with cylinder head grinding**

Cylinder block height (when new):

290 mm (11.4 inches)

4. Check cylinder walls for scratches and seizure. If defects are evident, replace or bore to oversize and replace pistons and piston rings.
5. Using a cylinder gauge, measure the cylinder bore and cylindrically. If worn badly, correct the cylinder to an oversize and replace the piston and piston rings. Measure at the points shown in the illustration.

Standard value:

Cylinder inner diameter 85.0 mm (3.35 inches)

Cylindrically 0.01 mm (0.0003 inch) or less

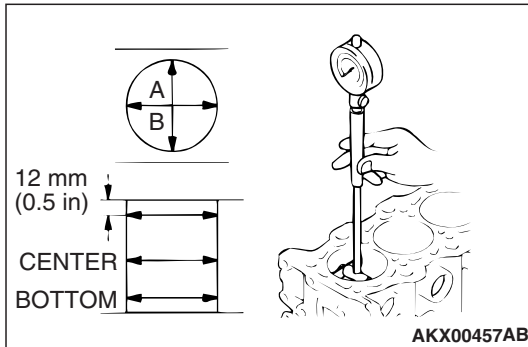

BORING CYLINDER

1. Oversize pistons to be used should be determined on the basis of the largest bore cylinder.

Piston size identification

SIZE	IDENTIFICATION MARK
0.50 mm (0.020 in) oversize diameter	50
1.00 mm (0.040 in) oversize diameter	100

NOTE: Size mark is stamped on the piston top.

2. Measure the outside diameter (OD) of the piston to be used. Measure it in thrust direction as shown.
3. Based on the measured piston OD, calculate the boring finish dimension.

**Boring finish dimension = Piston OD +
(clearance between piston OD and cylinder) –
0.02 mm (0.0008 inch) (honing margin)**

⚠ CAUTION

To prevent distortion that may result from temperature rise during honing, bore cylinders, working from number 2 to number 4 to number 1 to number 3.

4. Bore all cylinders to the calculated boring finish dimension.
5. Hone to the final finish dimension (piston OD + clearance between piston OD and cylinder).
6. Check the clearance between the piston and cylinder.

Clearance between piston and cylinder:

0.02 –0.04 mm (0.0008 –0.0015 inch)

NOTE: When boring cylinders, finish all of four cylinders to the same oversize. Do not bore only one cylinder to an oversize.

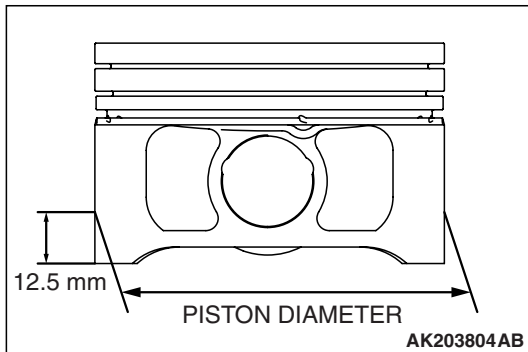

SPECIFICATIONS**FASTENER TIGHTENING SPECIFICATIONS**

M1113023401454

ITEM	SPECIFICATION
Generator and ignition system	
Auto-tensioner assembly bolt M8	24 ± 4 N· m (18 ± 2 ft-lb)
Auto-tensioner assembly bolt M10	44 ± 10 N· m (33 ± 6 ft-lb)
Center cover bolt	3.0 ± 0.5 N· m (27 ± 3 in-lb)
Crankshaft pulley bolt	25 ± 4 N· m (19 ± 2 ft-lb)
Generator brace bolt (flange bolt)	24 ± 4 N· m (18 ± 2 ft-lb)
Generator brace bolt (bolt, washer assembly M8 × 22)	22 ± 4 N· m (17 ± 2 ft-lb)
Generator brace bolt (bolt, washer assembly M8 × 32)	20 ± 2 N· m (15 ± 1 ft-lb)
Generator pivot nut	44 ± 10 N· m (33 ± 6 ft-lb)
Ignition coil bolt	10 ± 2 N· m (89 ± 17 in-lb)
Oil dipstick guide bolt	13 ± 1 N· m (115 ± 8 in-lb)
Spark plugs	25 ± 5 N· m (19 ± 3 ft-lb)
Water pump pulley bolt	8.8 ± 1.0 N· m (78 ± 8 in-lb)
Solenoid and vacuum hose	
Solenoid valve assembly bolt	9.0 ± 1.0 N· m (80 ± 8 in-lb)
Vacuum pipe and hose assembly bolt	11 ± 1 N· m (98 ± 8 in-lb)
Timing belt	
Auto-tensioner bolt	23 ± 3 N· m (17 ± 2 ft-lb)
Camshaft sprocket bolt	88 ± 10 N· m (65 ± 7 ft-lb)
Connector bracket bolt	11 ± 1 N· m (98 ± 8 in-lb)
Counterbalance shaft sprocket bolt	45 ± 3 N· m (33 ± 2 ft-lb)
Crankshaft angle sensors bolt	8.8 ± 1.0 N· m (78 ± 8 in-lb)
Crankshaft bolt	167 N· m (123 ft-lb)
Engine support bracket bolt	49 ± 5 N· m (36 ± 3 ft-lb)
Idler pulley	35 ± 6 N· m (26 ± 4 ft-lb)
Oil pump sprocket nut	54 ± 5 N· m (40 ± 3 ft-lb)
Plug cap	32 ± 2 N· m (24 ± 1 ft-lb)
Positive crankcase ventilation valve	10 ± 2 N· m (89 ± 17 in-lb)
Power steering pump bracket bolt	49 ± 9 N· m (36 ± 6 ft-lb)
Rocker cover bolt	3.5 ± 0.5 N· m (31 ± 4 in-lb)
Tensioner arm bolt	21 ± 4 N· m (16 ± 2 ft-lb)
Tensioner B bolt	19 ± 3 N· m (14 ± 2 ft-lb)
Tensioner pulley bolt	48 ± 5 N· m (36 ± 3 ft-lb)
Timing belt cover bolt (flange bolt)	11 ± 1 N· m (98 ± 8 in-lb)
Timing belt cover bolt (bolt, washer assembly)	9.0 ± 1.0 N· m (80 ± 8 in-lb)
V.V.T. sprocket bolt	65 ± 5 N· m (48 ± 3 ft-lb)

ITEM	SPECIFICATION
Fuel and emission parts	
Exhaust gas recirculation valve bolt	20 ± 2 N· m (15 ± 1 ft-lb)
Fuel pressure regulator bolt	8.8 ± 2.0 N· m (79 ± 16 in-lb)
Injector and fuel rail bolt	12 ± 1 N· m (107 ± 8 in-lb)
Throttle body bolt	19 ± 3 N· m (14 ± 2 ft-lb)
Intake manifold	
Engine hanger bolt	19 ± 3 N· m (26 ± 4 ft-lb)
Intake manifold bolt M8	20 ± 2 N· m (15 ± 1 ft-lb)
Intake manifold bolt, nut M10	36 ± 6 N· m (26 ± 4 ft-lb)
Intake manifold stay bolt	31 ± 3 N· m (23 ± 2 ft-lb)
Manifold absolute pressure sensor bolt	5.0 ± 1.0 N· m (45 ± 8 in-lb)
Exhaust manifold	
Air outlet fitting bolt	19 ± 1 N· m (14 ± 1 ft-lb)
Engine hanger bolt	19 ± 3 N· m (14 ± 2 ft-lb)
Exhaust fitting bolt	59 ± 5 N· m (44 ± 3 ft-lb)
Exhaust fitting bracket bolt	35 ± 6 N· m (26 ± 4 ft-lb)
Exhaust manifold heat protector bolt	23 ± 3 N· m (17 ± 2 ft-lb)
Exhaust manifold nut M8	33 ± 6 N· m (24 ± 4 ft-lb)
Exhaust manifold nut M10	55 ± 10 N· m (41 ± 6 ft-lb)
Oil pipe bolt (eye bolt M10)	17 ± 2 N· m (13 ± 1 ft-lb)
Oil pipe bolt (eye bolt M12)	31 ± 2 N· m (23 ± 1 ft-lb)
Oil pipe bolt (flange bolt)	11 ± 1 N· m (98 ± 8 in-lb)
Oil return pipe bolt (oil pan side)	14 ± 1 N· m (124 ± 8 in-lb)
Oil return pipe bolt (turbocharger side)	9.0 ± 1.0 N· m (80 ± 8 in-lb)
Oxygen sensor	44 ± 5 N· m (33 ± 3 ft-lb)
Turbocharger assembly and pipe assembly bolt, nut	64 ± 5 N· m (47 ± 3 ft-lb)
Turbocharger heat protector bolt	23 ± 3 N· m (17 ± 2 ft-lb)
Water pipe bolt (eye bolt M12)	42 ± 7 N· m (31 ± 5 ft-lb)
Water pipe bolt (flange bolt)	10 ± 1 N· m (89 ± 8 in-lb)
Water pump & water hose	
Engine coolant temperature gauge unit	11 ± 1 N· m (98 ± 8 in-lb)
Engine coolant temperature sensor	29 ± 10 N· m (22 ± 6 ft-lb)
Knock sensor bolt	23 ± 2 N· m (17 ± 2 ft-lb)
Thermostat housing bolt	23 ± 4 N· m (17 ± 2 ft-lb)
Water inlet pipe bolt M6	10 ± 1 N· m (89 ± 8 in-lb)
Water inlet pipe bolt M8	13 ± 2 N· m (115 ± 17 in-lb)
Water outlet fitting bolt	10 ± 1 N· m (89 ± 8 in-lb)
Water pump bolt	14 ± 1 N· m (124 ± 8 in-lb)

ITEM	SPECIFICATION
Rocker arms and camshafts	
Bearing cap bolt	20 ± 1 N· m (15 ± 1 ft-lb)
Camshaft position sensing cylinder bolt	22 ± 4 N· m (17 ± 2 ft-lb)
Camshaft position sensor bolt	10.8 ± 1.0 N· m (96 ± 8 in-lb)
Camshaft position sensor support bolt	14 ± 1 N· m (124 ± 8 in-lb)
Check valve	30 ± 3 N· m (22 ± 2 ft-lb)
Cover bolt	10 ± 2 N· m (89 ± 17 in-lb)
Eye bolt	42 ± 2 N· m (31 ± 2 ft-lb)
Oil delivery body bolt	11 ± 1 N· m (98 ± 8 in-lb)
Oil feeder control valve bolt	11 ± 1 N· m (98 ± 8 in-lb)
Oil pipe bolt	11 ± 1 N· m (98 ± 8 in-lb)
Oil pipe joint	30 ± 3 N· m (22 ± 2 ft-lb)
Cylinder head and valves	
Cylinder head bolt	78 ± 2 N· m (58 ± 1 ft-lb) → 0 N· m (0 in-lb) → 20 ± 2 N· m (15 ± 1 ft-lb) → +90° → +90°
Oil pan and oil pump	
Baffle plate bolt	22 ± 4 N· m (17 ± 2 ft-lb)
Drain plug	39 ± 5 N· m (29 ± 3 ft-lb)
Flange bolt	36 ± 3 N· m (27 ± 1 ft-lb)
Oil cooler by-pass valve	54 ± 5 N· m (40 ± 3 ft-lb)
Oil filter	14 ± 2 N· m (124 ± 17 in-lb)
Oil filter bracket bolt	19 ± 3 N· m (14 ± 2 ft-lb)
Oil pan bolt	9.0 ± 3.0 N· m (80 ± 26 in-lb)
Engine oil pressure switch	19 ± 3 N· m (14 ± 2 ft-lb)
Oil pump case bolt	23 ± 3 N· m (17 ± 2 ft-lb)
Oil pump cover bolt	17 ± 1 N· m (13 ± 1 ft-lb)
Oil pump cover screw	10 ± 2 N· m (89 ± 17 in-lb)
Oil screen bolt	19 ± 3 N· m (14 ± 2 ft-lb)
Plug cap	23 ± 3 N· m (17 ± 2 ft-lb)
Relief plug	44 ± 5 N· m (33 ± 3 ft-lb)
Pistons and connecting rod	
Connecting rod cap nut	20 ± 2 N· m (15 ± 1 ft-lb) → +90° to 94°
Crankshaft and cylinder block	
Beam bearing cap bolt	25 ± 2 N· m (18 ± 1 ft-lb) → +90°
Bell housing cover bolt	9.0 ± 1.0 N· m (80 ± 8 in-lb)
Check valve	32 ± 2 N· m (24 ± 1 ft-lb)
Flywheel bolt	132 ± 5 N· m (98 ± 3 ft-lb)
Oil seal case bolt	11 ± 1 N· m (98 ± 8 in-lb)
Rear plate bolt	11 ± 1 N· m (98 ± 8 in-lb)

GENERAL SPECIFICATIONS

M1113000201169

Descriptions		Specifications	
Type		In-line OHV, DOHC	
Number of cylinders		4	
Combustion chamber		Pentroof type	
Total displacement dm ³ (cubic inches)		1,997 (122)	
Cylinder bore mm (in)		85.0 (3.35)	
Piston stroke mm (in)		88.0 (3.46)	
Compression ratio		8.8	
Number of valve		Intake	2
		Exhaust	2
Valve timing	Intake valve	Opens (BTDC)	0° – 30°
		Closes (ABDC)	80° – 50°
	Exhaust valve	Opens (BBDC)	58°
		Closes (ATDC)	18°
Lubrication system		Pressure feed, full-flow filtration	
Oil pump type		Trochoid type	
Cooling system		Water-cooled forced circulation	
Water pump type		Centrifugal impeller type	

SERVICE SPECIFICATIONS

M1113000301218

Items		Standard value	Limit
Timing belt			
Auto tensioner rod length mm (in)		4.8 – 6.0 (0.19 – 0.21)	–
Auto tensioner rod production length mm (in)		12 (0.5)	–
Auto tensioner rod pushed-in amount [when pushed with a force of 98 to 196 N (22 to 44 lb)] mm (in)		1.0 (0.03) or less	–
Rocker arms and camshaft			
Camshaft cam height mm (in)	Intake	35.96 (1.42)	35.46 (1.40)
	Exhaust	35.49 (1.40)	34.99 (1.38)
Cylinder head and valve			
Cylinder head flatness of gasket surface mm (in)		Less than 0.03 (0.0012)	0.2 (0.008)
Cylinder head grinding limit of gasket surface mm (in) *Total resurfacing depth of both cylinder head and cylinder block		–	0.2* (0.008)
Cylinder head overall height mm (in)		119.9 – 120.1 (4.720 – 4.728)	–
Cylinder head bolt shank length mm (in)		–	99.4 (3.913)
Valve stem outside diameter mm (in)		6.0 (0.236)	–
Valve stem-to-guide clearance mm (in)	Intake	0.02 – 0.05 (0.0008 – 0.0020)	0.10 (0.0039)
	Exhaust	0.05 – 0.09 (0.0020 – 0.0035)	0.15 (0.0059)
Valve face angle		45° – 45.5°	–
Valve margin mm (in)	Intake	1.0 (0.039)	0.5 (0.020)
	Exhaust	1.5 (0.059)	1.0 (0.039)
Valve stem projection mm (in)	Intake	49.20 (1.9370)	49.70 (1.9567)
	Exhaust	48.40 (1.9055)	48.90 (1.9252)
Overall valve length mm (in)	Intake	109.50 (4.311)	109.00 (4.291)
	Exhaust	109.70 (4.319)	109.20 (4.299)
Valve spring free height mm (in)		50.4 (1.98)	49.4 (1.94)
Valve spring load/installed height N (lb) /mm (in)		279/40 (63/1.57)	–
Valve spring squareness		Max. 2°	4°
Valve seat contact width mm (in)		0.9 – 1.3 (0.035 – 0.051)	–
Valve guide inside diameter mm (in)		6.0 (0.236)	–
Valve guide projection mm (in)		19.5 (0.768)	–

Items		Standard value	Limit
Oversize valve guide hole diameter mm (in)	0.05 oversize diameter	12.05 –12.07 (0.4744 –0.4751)	–
	0.25 oversize diameter	12.25 –12.27 (0.4921 –0.4929)	–
	0.50 oversize diameter	12.50 –12.52 (0.4528 –0.4535)	–
Oversize intake valve seat hole diameter mm (in)	0.30 oversize diameter	35.30 –35.33 (1.3898 –1.3909)	–
	0.60 oversize diameter	35.60 –35.63 (1.4016 –1.4028)	–
Oversize exhaust valve seat hole diameter mm (in)	0.30 oversize diameter	33.30 –33.33 (1.3110 –1.3122)	–
	0.60 oversize diameter	33.60 –33.63 (1.3228 –1.3240)	–
Oil pump and oil pan			
Oil pump side clearance mm (in)	Drive gear	0.08 –0.14 (0.0031 –0.0055)	–
	Driven gear	0.06 –0.12 (0.0023 –0.0047)	–
Piston and connecting rod			
Piston outside diameter mm (in)		85.0 (3.35)	–
Piston ring side clearance mm (in)	No.1	0.03 – 0.07 (0.0012 –0.0028)	0.1 (0.0039)
	No.2	0.02 – 0.06 (0.0008 –0.0024)	0.1 (0.0039)
Piston ring end gap mm (in)	No.1	0.20 – 0.30 (0.0079 –0.0118)	0.8 (0.031)
	No.2	0.35 – 0.50 (0.0128 –0.0197)	0.8 (0.031)
	Oil ring	0.10 – 0.40 (0.0039 –0.0157)	1.0 (0.039)
Piston pin outside diameter mm (in)		22.0 (0.87)	–
Piston pin press-in load [at room temperature] N (lb)		7,350 –17,200 (1.653 –3.866)	–
Crankshaft pin oil clearance mm (in)		0.03 – 0.05 (0.0012 –0.0020)	0.1 (0.004)
Connecting rod big end side clearance mm (in)		0.10 – 0.25 (0.0039 –0.0098)	0.4 (0.016)

Items	Standard value	Limit
Crankshaft and cylinder block		
Crankshaft end play mm (in)	0.05 – 0.25 (0.0020 – 0.0098)	0.4 (0.016)
Crankshaft journal outside diameter mm (in)	57 (2.24)	–
Crankshaft pin outside diameter mm (in)	45 (1.77)	–
Crankshaft journal oil clearance mm (in)	0.02 – 0.04 (0.0008 – 0.0016)	0.1 (0.004)
Cylinder block gasket surface flatness mm (in)	0.05 (0.0020)	0.1 (0.004)
Cylinder block gasket surface grinding limit mm (in)	–	0.2 (0.008)
Cylinder block overall height mm (in)	290 (11.4)	–
Cylinder bore inside diameter mm (in)	85.0 (3.35)	–
Cylinder bore cylindricity mm (in)	0.01 (0.0004) or less	–
Piston-to-cylinder clearance mm (in)	0.02 – 0.04 (0.0008 – 0.0016)	–
Bearing cap bolt shank length mm (in)	–	71.1 (2.799)

SEALANTS AND ADHESIVES

M1113000500383

Items	Specified sealant	Quantity
Rocker cover	Mitsubishi Genuine Part No.MD970389 or equivalent	As required
Semicircular packing	3M™ AAD Part No.8672 or equivalent	As required
Engine support bracket	3M™ AAD Part No.8672 or equivalent	As required
Engine coolant temperature sensor	3M™ AAD Part No.8731 or equivalent	As required
Engine coolant temperature gauge unit	3M™ AAD Part No.8672 or equivalent	As required
Camshaft position sensor support	Mitsubishi Genuine Part No.MD970389 or equivalent	As required
Oil pan	Mitsubishi Genuine Part No.MD970389 or equivalent	As required
Oil pressure switch	3M™ AAD Part No.8672 or equivalent	As required
Oil seal case	Mitsubishi Genuine Part No.MD970389 or equivalent	As required